



CUSTOM COMPONENT BOOKLET



taylormadegolf.com

Updated as of 06/03/26

ADDITIONS

- p15-18 Spider Torched PVD/ZT MAX
- p77 2° Off-Axis Putter Grip, '26 Spider Pistol 1.0

DRVR/FW SHAFTS

HYBRID SHAFTS

IRON SHAFTS

WEDGES

PUTTERS

SWING GRIPS

PUTTER GRIPS

BUILD

JUNIOR



Qi4D LS

CLUB	LOFT	HAND	LIE	VOLUME	LENGTH	SW
Qi4D LS Driver	8°	RH	54°-58°	460CC	45.75"	D5
Qi4D LS Driver	9°	RH/LH	54°-58°	460CC	45.75"	D5
Qi4D LS Driver	10.5°	RH/LH	54°-58°	460CC	45.75"	D5



Qi4D

CLUB	LOFT	HAND	LIE	VOLUME	LENGTH	SW
Qi4D Driver	8°	RH	56°-60°	460CC	45.75"	D4
Qi4D Driver	9°	RH/LH	56°-60°	460CC	45.75"	D4
Qi4D Driver	10.5°	RH/LH	56°-60°	460CC	45.75"	D4
Qi4D Driver	12°	RH	56°-60°	460cc	45.75"	D4



Qi4D MAX

CLUB	LOFT	HAND	LIE	VOLUME	LENGTH	SW
Qi4D Max Driver	9°	RH/LH	58°- 62°	460CC	45.75"	D4
Qi4D Max Driver	10.5°	RH/LH	58°- 62°	460CC	45.75"	D4
Qi4D Max Driver	12°	RH/LH	58°- 62°	460CC	45.75"	D4



Qi4D MAX LITE

CLUB	LOFT	HAND	LIE	VOLUME	LENGTH	SW
Qi4D Max Lite Driver	10.5°	RH/LH	58°- 62°	460CC	45.75"	D0
Qi4D Max Lite Driver	12°	RH/LH	58°- 62°	460CC	45.75"	D0
Qi4D Max Women's Lite Driver	10.5°	RH	58°- 62°	460CC	44"	C3
Qi4D Max Women's Lite Driver	12°	RH	58°- 62°	460CC	44"	C3



DRIVER/WOODS

HYBRID

IRON

WEDGES

PUTTERS

GRIPS

PUTTER GRIPS

BUILD

JUNIOR

Custom Options available. Stated swingweight targets represent stock build configurations only.



Qi4D TOUR FAIRWAY

CLUB	NUMBER	LOFT	HAND	LIE	VOLUME	LENGTH	SW
Qi4D Tour Fairway	3	15°	RH/LH	57°-61°	175CC	43.25"	D3
Qi4D Tour Fairway	5	18°	RH/LH	57.5°-61.5°	150CC	42.25"	D3
Qi4D Tour Fairway	7	21°	RH	58°-62°	150CC	41.75"	D3



Qi4D FAIRWAY

CLUB	NUMBER	LOFT	HAND	LIE	VOLUME	LENGTH	SW
Qi4D Fairway	3	15°	RH/LH	56°-60°	185CC	43.25"	D3
Qi4D Fairway	3HL	16.5°	RH	56°-60°	185CC	43.25"	D3
Qi4D Fairway	5	18°	RH/LH	56.5° - 60.5°	170CC	42.25"	D3
Qi4D Fairway	7	21°	RH/LH	58° - 62°	170CC	41.75"	D3
Qi4D Fairway	9	24°	RH	58° - 62°	155CC	41.25"	D3



Qi4D MAX FAIRWAY

CLUB	NUMBER	LOFT	HAND	LIE	VOLUME	LENGTH	SW
Qi4D Max Fairway	3	15°	RH/LH	57° - 61°	200CC	43.25"	D2
Qi4D Max Fairway	5	18°	RH/LH	57.5° - 61.5°	190CC	42.25"	D2
Qi4D Max Fairway	7	21°	RH/LH	60°	170CC	41.75"	D2
Qi4D Max Fairway	9	24°	RH	60.5°	170CC	41.25"	D2



Qi4D MAX LITE FAIRWAY

CLUB	NUMBER	LOFT	HAND	LIE	VOLUME	LENGTH	SW
Qi4D Max Lite Fairway	3	15°	RH/LH	57° - 61°	200CC	43.25"	D0
Qi4D Max Lite Fairway	5	18°	RH/LH	57.5° - 61.5°	190CC	42.25"	D0
Qi4D Max Lite Fairway	7	21°	RH/LH	60°	170CC	41.75"	D0
Qi4D Max Lite Fairway	9	24°	RH	60.5°	170CC	41.25"	D0
Qi4D Max Lite Women's Fairway	3	15°	RH	57° - 61°	190CC	42"	C5
Qi4D Max Lite Women's Fairway	5	18°	RH	57.5° - 61.5°	175CC	41"	C5
Qi4D Max Lite Women's Fairway	7	21°	RH	60°	175CC	40.5"	C5



Custom Options available. Stated swingweight targets represent stock build configurations only.

Qi4D RESCUE™

CLUB	NUMBER	LOFT	HAND	LIE	LENGTH	SW
Qi4D Rescue	2	17°	RH	56°-60°	41.25"	D2
Qi4D Rescue	3	19°	RH/LH	56.5°-60.5°	40.75"	D2
Qi4D Rescue	4	22°	RH/LH	57-61°	40.25"	D2
Qi4D Rescue	5	25°	RH/LH	57.5-61.5°	39.75"	D2



Qi4D MAX RESCUE™

CLUB	NUMBER	LOFT	HAND	LIE	LENGTH	SW
Qi4D MAX RESCUE	3	20°	RH/LH	59°	40.75"	D2
Qi4D MAX RESCUE	4	23°	RH/LH	59.5°	40.25"	D2
Qi4D MAX RESCUE	5	26°	RH/LH	60°	39.75"	D2
Qi4D MAX RESCUE	6	30°	RH	60.5°	39.25"	D2
Qi4D MAX RESCUE	7	34°	RH	61°	38.75"	D2



Qi4D MAX LITE RESCUE™

CLUB	NUMBER	LOFT	HAND	LIE	LENGTH	SW
Qi4D MAX LITE RESCUE	4	23°	RH/LH	59.5°	40.25"	D0
Qi4D MAX LITE RESCUE	5	26°	RH/LH	60°	39.75"	D0
Qi4D MAX LITE RESCUE	6	30°	RH	60.5°	39.25"	D0
Qi4D MAX LITE RESCUE	7	34°	RH	61°	38.75"	D0
Qi4D MAX LITE WOMEN'S RESCUE	4	23°	RH/LH	59.5°	38.75"	C4
Qi4D MAX LITE WOMEN'S RESCUE	5	26°	RH/LH	60°	38.25"	C4
Qi4D MAX LITE WOMEN'S RESCUE	6	30°	RH	60.5°	37.75"	C4
Qi4D MAX LITE WOMEN'S RESCUE	7	34°	RH	61°	37.25"	C4



Custom Options available. Stated swingweight targets represent stock build configurations only.

2025 UTILITY IRONS



P·UDI

CLUB	NUMBER	LOFT	HAND	LIE	LENGTH	SW
P-UDI	2	18°	RH/LH	60°	39.75"	D2
P-UDI	3	20°	RH/LH	60.5°	39.25"	D2
P-UDI	4	22°	RH/LH	61°	38.75"	D2



P·DHY

CLUB	NUMBER	LOFT	HAND	LIE	LENGTH	SW
P-DHY	2	17°	RH/LH	60°	39.75"	D2
P-DHY	3	20°	RH/LH	60.5°	39.25"	D1
P-DHY	4	22°	RH/LH	61°	38.75"	D1



Custom Options available. Stated swingweight targets represent stock build configurations only.

DRVR/FW SHAFTS

HYBRID SHAFTS

IRON SHAFTS

WEDGES

PUTTERS

SWING GRIPS

PUTTER GRIPS

BUILD

JUNIOR



2026 IRONS



Qi MAX IRONS

CLUB	4	5	6	7	8	9	PW	AW	SW	LW
LOFT	18.5°	21°	24.0°	28°	32.5°	37°	43°	48°	54°	58°
LIE	61.5°	62.0°	62.5°	63.0°	63.5°	64°	64.5°	64.5°	64.5°	64.5°
LENGTH MEN'S	39.125"	38.5"	37.88"	37.25"	36.75"	36.25"	35.75"	35.5"	35.25"	35"
SWINGWEIGHT MEN'S (STEEL)	D1	D1	D1	D1	D1	D1	D1	D1	D2	D3
SWINGWEIGHT MEN'S (GRAPHITE)	D0	D0	D0	D0	D0	D0	D0	D0	D1	D2
HAND	RH/LH	RH/LH	RH/LH	RH/LH	RH/LH	RH/LH	RH/LH	RH/LH	RH/LH	RH



Qi MAX HL IRONS

CLUB	5	6	7	8	9	PW	AW	SW
LOFT	23.5°	27°	31°	35.5°	40°	44.5°	50°	55°
LIE	62.0°	62.5°	63.0°	63.5°	64°	64.5°	64.5°	64.5°
LENGTH MEN'S	38.5"	37.88"	37.25"	36.75"	36.25"	35.75"	35.5"	35.25"
LENGTH WOMEN'S	37.5"	36.88"	36.25"	35.75"	35.25"	34.75"	34.5"	34.25"
SWINGWEIGHT MEN'S (STEEL)	C9	C9	C9	C9	C9	C9	C9	D0
SWINGWEIGHT MEN'S (GRAPHITE)	D0	D0	D0	D0	D0	D0	D0	D1
SWINGWEIGHT WOMEN'S	C0	C0	C0	C0	C0	C0	C0	C1
HAND	RH/LH	RH/LH	RH/LH	RH/LH	RH/LH	RH/LH	RH/LH	RH/LH



P.790

CLUB	4	5	6	7	8	9	PW	AW
LOFT	20°	23°	26.5°	30°	34°	39°	44°	49°
LIE	61.0°	61.5°	62.0°	62.5°	63.0°	63.5°	64°	64°
LENGTH MEN'S (STEEL)	38.50"	38.00"	37.50"	37.00"	36.50"	36.00"	35.75"	35.50"
SWINGWEIGHT MEN'S (STEEL)	D2	D2	D2	D2	D2	D2	D3	D3
SWINGWEIGHT MEN'S (GRAPHITE)	D0	D0	D0	D0	D0	D0	D1	D1
LENGTH WOMEN'S (CUSTOM ONLY)	37.50"	37.00"	36.50"	36.00"	35.50"	35.00"	34.75"	34.50"
HAND	RH/LH	RH/LH	RH/LH	RH/LH	RH/LH	RH/LH	RH/LH	RH/LH



Custom Options available. Stated swingweight targets represent stock build configurations only.

P.770

CLUB	3	4	5	6	7	8	9	PW	AW
LOFT	19°	22°	25.5°	29.0°	33°	37°	41°	45°	50°
LIE	60.5°	61°	61.5°	62.0°	62.5°	63.0°	63.5°	64°	64°
LENGTH MEN'S	39"	38.5"	38"	37.5"	37"	36.5"	36"	35.75"	35.5"
SWINGWEIGHT MEN'S (ST/GR)	D2	D2	D2	D2	D2	D2	D2	D3	D3
HAND	RH/LH	RH/LH	RH/LH	RH/LH	RH/LH	RH/LH	RH/LH	RH/LH	RH



P.7CB

CLUB	3	4	5	6	7	8	9	PW	AW
LOFT	20°	23°	26°	29°	33°	37°	41°	46°	51°
LIE	60.5°	61°	61.5°	62.0°	62.5°	63.0°	63.5°	64°	64°
LENGTH MEN'S	39"	38.5"	38"	37.5"	37"	36.5"	36"	35.75"	35.5"
SWINGWEIGHT MEN'S (ST/GR)	D3	D3	D3	D3	D3	D3	D3	D4	D4
HAND	RH/LH	RH/LH	RH/LH	RH/LH	RH/LH	RH/LH	RH/LH	RH/LH	RH



P.7MB

CLUB	3	4	5	6	7	8	9	PW
LOFT	20°	23°	26°	30°	34°	38°	42.5°	47°
LIE	60.5°	61°	61.5°	62°	62.5°	63°	63.5°	64°
LENGTH MEN'S	39"	38.5"	38"	37.5"	37"	36.5"	36"	35.75"
SWINGWEIGHT MEN'S (ST/GR)	D2	D2	D2	D2	D2	D2	D2	D3
HAND	RH/LH	RH/LH	RH/LH	RH/LH	RH/LH	RH/LH	RH/LH	RH/LH



P.7TW

CLUB	3	4	5	6	7	8	9	PW
LOFT	21°	24°	27°	31°	35°	39°	43°	47°
LIE	59.5°	60°	60.5°	61°	61.5°	62.5°	63°	63.5°
LENGTH MEN'S (ST)	39.00"	38.50"	38.00"	37.50"	37.00"	36.50"	36.00"	35.75"
SWINGWEIGHT MEN'S (ST)	D3	D3	D3	D3	D3	D3	D3	D3
HAND	RH	RH	RH	RH	RH	RH	RH	RH



Custom Options available. Stated swingweight targets represent stock build configurations only.

P•700 SERIES COMBO GUIDE



For players committed to the grind, P-Series awaits. An added benefit is the ability to combo, or mix and match, iron sets. This chart will help identify how your lofts should be adjusted for proper gapping based on your desired level of forgiveness.

FORGIVENESS LEVEL 1	ADJUSTED LOFTS						STOCK LOFTS			
	P7MB	P7CB	P7CB	P770	P770	P790	P7MB	P7CB	P770	P790
	3		STD		STD			20°	20°	19°
4		STD		STD		1° Weak	23°	23°	22°	20°
5	STD		0.5° Strong		0.5° Strong		26°	26°	25.5°	23°
6	STD		STD		STD		30°	29°	29°	26.5°
7	STD		STD		STD		34°	33°	33°	30°
8	STD		STD		STD		38°	37°	37°	34°
9	STD		STD		STD		42.5°	41°	41°	39°
P	STD		STD		STD		47°	46°	45°	44°
A					STD			51°	50°	49°

FORGIVENESS LEVEL 2	ADJUSTED LOFTS						STOCK LOFTS			
	P7MB	P7CB	P7CB	P770	P770	P790	P7MB	P7CB	P770	P790
	3		STD		STD			20°	20°	19°
4		STD		STD		1° Weak	23°	23°	22°	20°
5		STD		STD		2° Weak	26°	26°	25.5°	23°
6	STD		STD		STD		30°	29°	29°	26.5°
7	STD		STD		STD		34°	33°	33°	30°
8	STD		STD		STD		38°	37°	37°	34°
9	STD		STD		STD		42.5°	41°	41°	39°
P	STD		STD		STD		47°	46°	45°	44°
A			STD		STD			51°	50°	49°

FORGIVENESS LEVEL 3	ADJUSTED LOFTS						STOCK LOFTS			
	P7MB	P7CB	P7CB	P770	P770	P790	P7MB	P7CB	P770	P790
	3		STD		STD			20°	20°	19°
4		STD		STD		1° Weak	23°	23°	22°	20°
5		STD		STD		1.5° Weak	26°	26°	25.5°	23°
6		1° Weak		STD		2° Weak	30°	29°	29°	26.5°
7	STD		STD		0.5° Strong		34°	33°	33°	30°
8	STD		STD		0.5° Strong		38°	37°	37°	34°
9	STD		STD		0.5° Strong		42.5°	41°	41°	39°
P	STD		STD		STD		47°	46°	45°	44°
A			STD		STD			51°	50°	49°

FORGIVENESS LEVEL 4	ADJUSTED LOFTS						STOCK LOFTS			
	P7MB	P7CB	P7CB	P770	P770	P790	P7MB	P7CB	P770	P790
	3		STD		STD			20°	20°	19°
4		STD		STD		1° Weak	23°	23°	22°	20°
5		STD		STD		1.5° Weak	26°	26°	25.5°	23°
6		1° Weak		STD		1.5° Weak	30°	29°	29°	26.5°
7	STD			STD		2° Weak	34°	33°	33°	30°
8	STD		STD		1° Strong		38°	37°	37°	34°
9	STD		STD		0.5° Strong		42.5°	41°	41°	39°
P	STD		STD		STD		47°	46°	45°	44°
A			STD		STD			51°	50°	49°



DRIVER/IRON SHAFTS

HYBRID SHAFTS

IRON SHAFTS

WEDGES

PUTTERS

SWING GRIPS

PUTTER GRIPS

BUILD

JUNIOR

LEARN IT



- P·UDI:**
 - Tour inspired shape
 - Penetrating ball flight
 - Blend of control and workability
- P·DHY:**
 - Shallower face height and increased sole width
 - Mid-to-high launch and mid-range spin
 - Blend of forgiveness and playability
- Qi4D RESCUE™:**
 - Mid profile
 - Mid-launch, mid-spin
 - Adjustable loft sleeve
- Qi4D MAX RESCUE™:**
 - Large confidence inspiring profile
 - Long and versatile shape
 - High launch, mid-spin
- Qi4D MAX LITE RESCUE™:**
 - Large confidence inspiring shape
 - Ultra-lightweight, long, versatile
 - High launch, mid-spin

COMPARE IT

	P·UDI	P·DHY	Qi4D RESCUE™	Qi4D MAX RESCUE™	Qi4D MAX LITE RESCUE™
LOFTS	2-17°, 3-20°, 4-22°	2-17°, 3-19°, 4-22°	2-17°, 3-19.5°, 4-22°, 5-25°	3-20°, 4-23°, 5-26°, 6-30°, 7-34°	4-23°, 5-26°, 6-30°, 7-34°
HAND	RH - 2, 3, 4 LH - 2, 3, 4	RH - 2, 3, 4 LH - 2, 3, 4	RH - 2, 3, 4, 5 LH - 3, 4, 5	RH - 3, 4, 5, 6, 7 LH - 3, 4, 5	RH - 4, 5, 6, 7 LH - 4, 5
LAUNCH	MID-LOW	MID-HIGH	MID	HIGH	HIGH
SPIN	MID	MID	MID-LOW	MID	MID
HANDICAP	0-15	0-20	0-30	0-30	0-30
TEE SHOT	★★★★★	★★★★★	★★★★★	★★★★★	★★★★★
FAIRWAY SHOT	★★★★★	★★★★★	★★★★★	★★★★★	★★★★★
ROUGH/OTHER	★★★★★	★★★★	★★★★★	★★★★★	★★★★★

SELECT IT

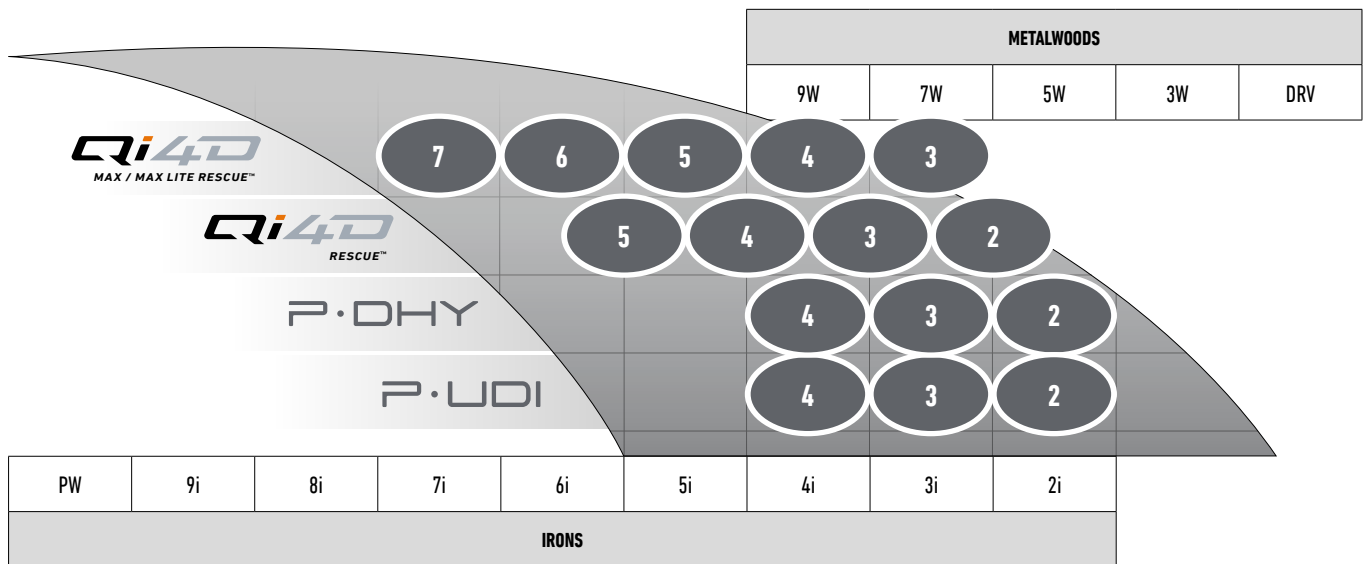

2026 WEDGES



CLUB	LOFT	LENGTH	BOUNCE	LIE	SWINGWEIGHT	SATIN CHROME	CHARCOAL
LB	56.08°	35.25"	8°	64°	D5	RH/LH	-
	58.08°	35"	8°	64°	D5	RH/LH	-
	60.08°	35"	8°	64°	D5	RH/LH	-
SC	54.10°	35.25"	10°	64°	D5	RH	-
	56.10°	35.25"	10°	64°	D5	RH/LH	RH
	58.09°	35"	9°	64°	D5	RH	-
	60.09°	35"	9°	64°	D5	RH/LH	RH
SB*	46.09°	35.75"	9°	64°	D3	RH	-
	48.09°	35.75"	9°	64°	D3	RH	-
	50.09°	35.50"	9°	64°	D3	RH/LH	RH
	52.09°	35.50"	9°	64°	D3	RH/LH	RH/LH
	54.12°	35.25"	12°	64°	D5	RH/LH	RH
	56.12°	35.25"	12°	64°	D5	RH/LH	RH/LH
	58.10°	35"	10°	64°	D5	RH/LH	RH
SX	60.10°	35"	10°	64°	D5	RH/LH	RH/LH
	58.11°	35"	11°	64°	D5	RH	-
HB	60.11°	35"	11°	64°	D5	RH/LH	RH
	54.13°	35.25"	13°	64°	D5	RH	-
	56.14°	35.25"	14°	64°	D5	RH	-
	58.12°	35"	12°	64°	D5	RH	-
	60.12°	35"	12°	64°	D5	RH/LH	-
TW	56.12°	35.25"	12°	64°	D5	RH	-
	60.11°	35"	11°	64°	D5	RH	-

DRVR/FW SHAFTS

HYBRID SHAFTS

IRON SHAFTS

WEDGES

PUTTERS

SWING GRIPS

PUTTER GRIPS

BUILD

JUNIOR



MILLED GRIND 5

LB



Designed for players who want the leading edge to sit low to the ground in a variety of face positions. Intended for shallow swing styles and tight, firm conditions.

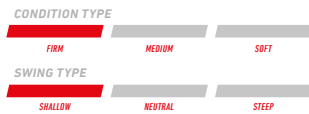

SC



Built for the golfer who plays in all types of conditions and demands ultimate greenside versatility. Also provides consistent stability on full shots with heel and toe relief when manipulating the face.

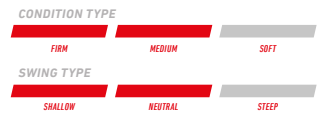

SB



Great fit for an array of swing styles and turf conditions. A gentle 4-way camber creates smooth turf interaction with forgiveness on partial swings and bunker shots.

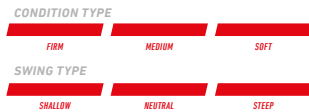

SX



Our widest sole option uses increased sole curvature to glide through any turf condition with unmatched consistency from the bunker. Our signature "Reverse-C" trailing edge relief is designed to keep the bounce consistent as you manipulate the face.

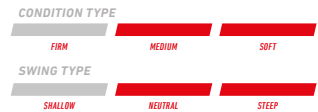

HB



A high bounce sole option designed with versatility as demanded by better players. Unique heel relief and increased bounce towards the toe is great for softer conditions or steeper swings.

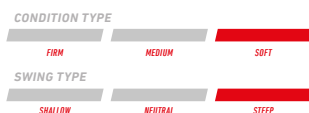

TW



Updated to match Tiger's recent wedge preferences. A new leading edge blend with increased effective bounce in the heel.

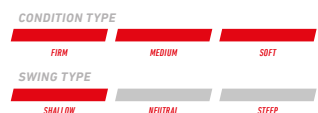

2026 WEDGES



HI-TOE⁴



CLUB	LOFT	LENGTH	BOUNCE	LIE	HAND	SWINGWEIGHT	SHAFT	SCORING LINES	FINISH
ATS	50°	35.50"	9°	64°	RH/LH	D5	TRUE TEMPER DYNAMIC GOLD TOUR ISSUE 115G	TRADITIONAL	COPPER
	52°	35.50"	9°	64°	RH/LH	D5	TRUE TEMPER DYNAMIC GOLD TOUR ISSUE 115G	TRADITIONAL	COPPER
	54°	35.25"	10°	64°	RH/LH	D5	TRUE TEMPER DYNAMIC GOLD TOUR ISSUE 115G	FULL FACE	COPPER
	56°	35.25"	10°	64°	RH/LH	D5	TRUE TEMPER DYNAMIC GOLD TOUR ISSUE 115G	FULL FACE	COPPER
	58°	35.00"	10°	64°	RH/LH	D5	TRUE TEMPER DYNAMIC GOLD TOUR ISSUE 115G	FULL FACE	COPPER
	60°	35.00"	10°	64°	RH/LH	D5	TRUE TEMPER DYNAMIC GOLD TOUR ISSUE 115G	FULL FACE	COPPER
ATV	56°	35.25"	11°	64°	RH/LH	D5	TRUE TEMPER DYNAMIC GOLD TOUR ISSUE 115G	FULL FACE	COPPER
	58°	35.00"	11°	64°	RH/LH	D5	TRUE TEMPER DYNAMIC GOLD TOUR ISSUE 115G	FULL FACE	COPPER
	60°	35.00"	11°	64°	RH/LH	D5	TRUE TEMPER DYNAMIC GOLD TOUR ISSUE 115G	FULL FACE	COPPER
ATX	56°	35.25"	12°	64°	RH/LH	D5	TRUE TEMPER DYNAMIC GOLD TOUR ISSUE 115G	FULL FACE	COPPER
	58°	35.00"	12°	64°	RH/LH	D5	TRUE TEMPER DYNAMIC GOLD TOUR ISSUE 115G	FULL FACE	COPPER
	60°	35.00"	12°	64°	RH/LH	D5	TRUE TEMPER DYNAMIC GOLD TOUR ISSUE 115G	FULL FACE	COPPER
ATC	58°	35.00"	8°	64°	RH/LH	D5	TRUE TEMPER DYNAMIC GOLD TOUR ISSUE 115G	FULL FACE	COPPER
	60°	35.00"	8°	64°	RH/LH	D5	TRUE TEMPER DYNAMIC GOLD TOUR ISSUE 115G	FULL FACE	COPPER
ATW	56°	35.25"	14°	64°	RH/LH	D3	TRUE TEMPER DYNAMIC GOLD TOUR ISSUE 115G	FULL FACE	COPPER
	58°	35.00"	14°	64°	RH/LH	D3	TRUE TEMPER DYNAMIC GOLD TOUR ISSUE 115G	FULL FACE	COPPER
	60°	35.00"	14°	64°	RH/LH	D3	TRUE TEMPER DYNAMIC GOLD TOUR ISSUE 115G	FULL FACE	COPPER

DRIVER/WY SHAFTS

HYBRID SHAFTS

IRON SHAFTS

WEDGES

PUTTERS

SWING GRIPS

PUTTER GRIPS

BUILD

JUNIOR



HI-TOE⁴



AT5

CONDITION TYPE



SWING TYPE



An increased 4-way camber is a staple in this sole design providing versatility for manufacturing shots with an open or closed face.



ATV

CONDITION TYPE



SWING TYPE



A unique asymmetric bounce and concave sole creates a multifunctional design for crisp, clean contact off tight lies while playing with more effective bounce in the open face position for all around versatility.



ATX

CONDITION TYPE



SWING TYPE



One of our most forgiving sole designs using a 3 surface sole that plays with mid range bounce. The leading edge prevents digging in softer conditions, while the mid sole ensures stability and an aggressive trailing edge creates a quick exit from the turf.



ATC

CONDITION TYPE



SWING TYPE



A low bounce wedge packed with versatility. A narrow split sole design with a low leading edge, and healthy heel/toe relief.



ATW

CONDITION TYPE



SWING TYPE



Wide sole designed with a high effective bounce. It is designed to inspire confidence and provide maximum forgiveness, especially out of soft conditions and bunkers.

LIGHT TURF INTERACTION

HEAVY TURF INTERACTION

2026 PUTTERS



Spider
TOUR SERIES

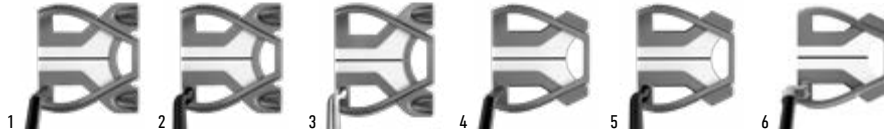

IMAGE	TYPE	HOSEL	HAND	TOE HANG	OFFSET	LOFT	LIE	INSERT
1	SPIDER TOUR #3	SMALL SLANT	RH/LH	29°	FULL SHAFT	3°	70°	TPU PURE ROLL
2	SPIDER TOUR DOUBLE BEND	DOUBLE BEND	RH/LH	0°	HALF SHAFT	3°	70°	TPU PURE ROLL
3	SPIDER TOUR S	DOUBLE BEND	RH/LH	0°	HALF SHAFT	3°	70°	TPU PURE ROLL
4	SPIDER TOUR X #3	SMALL SLANT	RH/LH	30°	HALF SHAFT	3°	70°	TPU PURE ROLL
5	SPIDER TOUR X DOUBLE BEND	DOUBLE BEND	RH/LH	0°	FULL SHAFT	3°	70°	TPU PURE ROLL
6	SPIDER TOUR X #1	L-NECK (#1)	RH/LH	21°	FULL SHAFT	3°	70°	TPU PURE ROLL

Spider
TOUR SERIES
BLACK

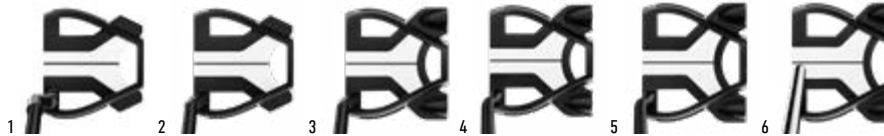

IMAGE	TYPE	HOSEL	HAND	TOE HANG	OFFSET	LOFT	LIE	INSERT
1	SPIDER TOUR X #1 BLACK	L-NECK (#1)	RH/LH	21°	FULL SHAFT	3°	70°	TPU PURE ROLL
2	SPIDER TOUR X #3 BLACK	SMALL SLANT	RH/LH	30°	HALF SHAFT	3°	70°	TPU PURE ROLL
3	SPIDER TOUR #3 BLACK	SMALL SLANT	RH/LH	29°	FULL SHAFT	3°	70°	TPU PURE ROLL
4	SPIDER TOUR DOUBLE BEND	DOUBLE BEND	RH	0°	HALF SHAFT	3°	70°	TPU PURE ROLL
5	SPIDER TOUR S BLACK	DOUBLE BEND	RH/LH	0°	HALF SHAFT	3°	70°	TPU PURE ROLL
6	SPIDER TOUR S BLACK CS LONG*	CENTER SHAFT	RH	0°	FULL SHAFT	3°	70°	TPU PURE ROLL

Items in RED will be offered in custom only

*Not available for custom

Spider
TOUR
TORCHED



IMAGE	TYPE	ALIGNMENT	HOSEL	TOE HANG	OFFSET	HAND & LENGTH	CG LOCATION	LOFT/LIE
1	Spider Tour V	Single Line	L-Neck (#1)	33°	FULL SHAFT	35", 34", 33"	21mm	3°/70°
2	Spider Tour F	Single Line	L-Neck (#1)	33°	FULL SHAFT	35", 34", 33"	22mm	3°/70°
3	Spider Tour F	Single Line	Double Bend (DB)	Face-Balanced	HALF SHAFT	35", 34", 33"	22mm	3°/70°
4	Spider Tour X	TruePath	L-Neck (#1)	21°	FULL SHAFT	35", 34", 33"	36mm	3°/70°
5	Spider Tour X	Single Line	Small Slant (#3)	30°	HALF SHAFT	35", 34", 33"	34mm	3°/70°
6	Spider Tour X	TruePath	Small Slant (#3)	30°	HALF SHAFT	35", 34", 33"	34mm	3°/70°
7	Spider Tour X	TruePath	Double Bend (DB)	Face-Balanced	HALF SHAFT	35", 34", 33"	36mm	3°/70°
8	Spider Tour	Single Line	L-Neck (#1)	23°	FULL SHAFT	35", 34", 33"	36mm	3°/70°
9	Spider Tour	TruePath	Small Slant (#3)	30°	HALF SHAFT	35", 34", 33"	36mm	3°/70°
10	Spider Tour Counterbalance	TruePath	Double Bend (DB)	Face-Balanced	FULL SHAFT	35", 34", 33"	36mm	3°/70°

Lengths highlighted in RED are offered in RH Only

Custom options available

2026 PUTTERS



IMAGE	TYPE	HOSEL	HAND	TOE HANG	OFFSET	LOFT	LIE	INSERT	HEADWEIGHT
1, 2	SPIDER ZT STANDARD	SHAFT IN	RH/LH	90° TOE UP	ON SET	2.5°	70°	BLACK PURE ROLL	370g
1, 2	SPIDER ZT COUNTER BALANCE	SHAFT IN	RH/LH	90° TOE UP	ON SET	2.5°	70°	BLACK PURE ROLL	395g
1	SPIDER ZT LONG*	SHAFT IN	RH	90° TOE UP	ON SET	2.5°	79°	BLACK PURE ROLL	470g
3	SPIDER ZT MAX STANDARD	SHAFT IN	RH/LH	90° TOE UP	ON SET	3.5°	70°	BLACK PURE ROLL	379g
3	SPIDER ZT MAX STANDARD	SHAFT IN	RH	90° TOE UP	ON SET	3.5°	70°	BLACK PURE ROLL	379g
3	SPIDER ZT MAX CB	SHAFT IN	RH	90° TOE UP	ON SET	3.5°	70°	BLACK PURE ROLL	398g
3	SPIDER ZT MAX CB	SHAFT IN	RH/LH	90° TOE UP	ON SET	3.5°	70°	BLACK PURE ROLL	398g
3	SPIDER ZT MAX LONG	SHAFT IN	RH	90° TOE UP	ON SET	3°	79°	BLACK PURE ROLL	472g

*Not available in Custom, Spider ZT Black not available in Long

** TSS Weights should not be adjusted. These are used to balance the putter in the toe up position and factor in changes in length and grip.



IMAGE	MODEL	HOSEL	TOE HANG	OFFSET	HAND & LENGTH	LOFT	LIE
1	SOTO 12	L-NECK	43°	FULL-SHAFT	RH: 35", 34" / LH: 34", 35"	3.5°	70°
2	SOTO 92	SHORT CURVE	55°	3/4 SHAFT	RH 35", 34"	3.5°	70°
3	JUNO 12	L-NECK	43°	FULL-SHAFT	RH: 35", 34" / LH: 34", 35"	3.5°	70°
4	JUNO 92	SHORT CURVE	55°	3/4 SHAFT	RH 35", 34"	3.5°	70°
5	DEL MONTE 12	L-NECK	40°	FULL-SHAFT	RH: 35", 34" / LH: 34", 35"	3.5°	70°
6	BANDON 12	L-NECK	33°	FULL-SHAFT	RH: 35", 34" / LH: 34", 35"	3°	70°
7	BANDON 72	SINGLE BEND	FACE-BALANCED	HALF-SHAFT	RH: 35", 34"	3°	70°
8	ARDMORE 12	L-NECK	31°	FULL-SHAFT	RH: 35", 34" / LH: 34", 35"	3°	70°
9	ARDMORE 72	SINGLE BEND	FACE-BALANCED	HALF-SHAFT	RH: 35", 34"	3°	70°

Custom Offering only

PUTTER - WEIGHT TABLES



PUTTER LENGTH	ADJUSTABLE WEIGHT					
	SPIDER TOUR #3	SPIDER TOUR DOUBLE BEND	SPIDER TOUR X #3	SPIDER TOUR X #3 BLACK	SPIDER TOUR X DOUBLE BEND	SPIDER TOUR X #1
37"	1g	1g	1g	1g	1g	4g
36.75"	1g	1g	1g	1g	1g	4g
36.5"	1g	1g	1g	1g	1g	4g
36.25"	1g	1g	1g	1g	1g	4g
36"	1g	1g	1g	1g	1g	4g
35.75"	1g	1g	1g	1g	1g	4g
35.50"	1g	1g	1g	1g	1g	4g
35.25"	1g	1g	1g	1g	1g	4g
35"	1g	1g	1g	1g	1g	4g
34.75"	1g	1g	1g	1g	1g	4g
34.5"	1g	1g	1g	1g	1g	4g
34.25"	6g	6g	6g	1g	6g	4g
34"	6g	6g	6g	6g	6g	9g
33.75"	6g	6g	6g	6g	6g	9g
33.5"	6g	6g	6g	6g	6g	9g
33.25"	11g	11g	11g	6g	11g	9g
33"	11g	11g	11g	6g	11g	9g
32.75"	11g	11g	11g	6g	11g	9g
32.5"	11g	11g	11g	6g	11g	9g
32.25"	11g	11g	11g	6g	11g	9g
32"	11g	11g	11g	6g	11g	9g

DRVR/FW SHAFTS

HYBRID SHAFTS

IRON SHAFTS

WEDGES

PUTTERS

SWING GRIPS

PUTTER GRIPS

BUILD

JUNIOR



PUTTER COMPARISON DATA SHEET



MODEL	SHAFT OFFSET	HOSEL	TOE HANG	CG LOCATION	
JUNO 12	FULL SHAFT	L-NECK	43	10.7MM	<p>EASIEST TO CLOSE Rotates easier through impact zone</p> <p>HARDEST TO CLOSE Resists rotation through impact zone</p>
SOTO 12	FULL SHAFT	L-NECK	43	10.7MM	
JUNO 92	3/4 SHAFT	SHORT CURVE	55	12.0MM	
SOTO 92	3/4 SHAFT	SHORT CURVE	55	12.0MM	
DEL MONTE 12	FULL SHAFT	L-NECK	40	12.9MM	
BANDON 72	HALF SHAFT	SINGLE BEND	0	20.5MM	
ARDMORE 72	HALF SHAFT	SINGLE BEND	0	22MM	
ARDMORE 12	FULL SHAFT	L-NECK	31	21.8MM	
BANDON 12	FULL SHAFT	L-NECK	33	20.3MM	
SPIDER TOUR F	FULL SHAFT	DOUBLE BEND	0	22MM	
SPIDER TOUR V	FULL SHAFT	L-NECK	33	21MM	
SPIDER TOUR F	FULL SHAFT	L-NECK	33	22MM	
SPIDER ZT	ON SET	SHAFT IN	90° TOE UP	25 MM	
SPIDER ZT COUNTER BALANCE	ON SET	SHAFT IN	90° TOE UP	25 MM	
SPIDER ZT LONG	ON SET	SHAFT IN	90° TOE UP	26 MM	
SPIDER TOUR X DOUBLE BEND	HALF SHAFT	DOUBLE BEND	0	33MM	
SPIDER TOUR X	FULL SHAFT	L-NECK	21	33MM	
SPIDER TOUR X	HALF SHAFT	SMALL SLANT	30	33MM	
SPIDER TOUR COUNTER BALANCE	FULL SHAFT	DOUBLE BEND	0	35MM	
SPIDER ZT MAX	ON SET	SHAFT IN	90° TOE UP	35 MM	
SPIDER ZT MAX COUNTER BALANCE	ON SET	SHAFT IN	90° TOE UP	35 MM	
SPIDER TOUR	FULL SHAFT	L-NECK	23	36 MM	
SPIDER TOUR	HALF SHAFT	SMALL SLANT	29	35MM	
SPIDER ZT MAX LONG	ON SET	SHAFT IN	90° TOE UP	35 MM	

DRIVER/WY SHAFTS

HYBRID SHAFTS

IRON SHAFTS

WEDGES

PUTTERS

SWING GRIPS

PUTTER GRIPS

BUILD

JUNIOR



PRODUCT COMPARISON DATA SHEET



DRIVERS	Qi4D LS	Qi4D DRIVER	Qi4D MAX DRIVER	Qi4D MAX LITE DRIVER
FORGIVENESS	★★★★	★★★★★	★★★★★★	★★★★★
BALL SPEED	FASTEST	FASTEST	FAST	FAST
SPIN	ULTRA-LOW	MID	MID	MID
LAUNCH	LOW	MID	MID-HIGH	HIGH
ADJUSTABILITY	2 TAS WEIGHTS	QUAD WEIGHTING	2 TAS WEIGHTS	1 TAS WEIGHT
HEAD SHAPE & SIZE	COMPACT / 460CC	MODERN /460CC	MAX / 460CC	MAX/460CC



FAIRWAYS	Qi4D TOUR FAIRWAY	Qi4D FAIRWAY	Qi4D MAX FAIRWAY	Qi4D MAX LITE FAIRWAY
FORGIVENESS	★★★★	★★★★★	★★★★★★	★★★★★
SPIN	MID-ADJUSTABLE	MID	MID-HIGH	MID-HIGH
LAUNCH	MID-LOW/ADJUSTABLE	MID/ADJUSTABLE	HIGH/ADJUSTABLE*	HIGH/ADJUSTABLE*
ADJUSTABILITY	3 TAS WEIGHTS	1 TAS WEIGHT	1 TAS WEIGHT	1 TAS WEIGHT
HEAD SIZE	175CC	185CC	200CC	200CC
ADJUSTABLE LOFT SLEEVE	3,5,7	3,3HL, 5,7,9	3, 5	3, 5



RESCUES	Qi4D RESCUE	Qi4D MAX RESCUE	Qi4D MAX LITE RESCUE
FORGIVENESS	★★★★★	★★★★★★	★★★★★
SPIN	ADJUSTABLE	MID	HIGH
LAUNCH	MID	MID	MID
ADJUSTABILITY	1 TAS WEIGHT	1 TAS WEIGHT	1 TAS WEIGHT
ADJUSTABLE LOFT SLEEVE	2,3,4,5	N/A	N/A



UTILITY	P-DHY	P-UDI
FORGIVENESS	HIGH	MID
LAUNCH	MID-HIGH	MID-LOW
SPIN	MID	MID
BIASED	NEUTRAL	NEUTRAL

DRIVER/WY SHAFTS

HYBRID SHAFTS

IRON SHAFTS

WEDGES

PUTTERS

SWING GRIPS

PUTTER GRIPS

BUILD

JUNIOR



PRODUCT COMPARISON DATA SHEET



IRONS	P-7TW	P-7MB	P-7CB	P-770	P-790	Qi MAX	Qi MAX HL
STYLE	PLAYERS	PLAYERS	PLAYERS	MODERN PLAYERS	PLAYERS DISTANCE	GAME IMPROVEMENT	GAME IMPROVEMENT
FORGIVENESS	LOW	LOW	LOW-MID	MID	MID-HIGH	HIGH	HIGHEST
TRAJECTORY	MID	MID	MID	MID	MID-HIGH	HIGH	HIGHEST
WORKABILITY	HIGH	HIGH	HIGH	MID-HIGH	MID	LOW	LOW
DISTANCE	MID	MID	MID	MID-LONG	LONG	LONGEST	LONGEST



WEDGE	HI-TOE 4	MILLED GRIND 5
SHAPE	MODERN	CLASSIC
LAUNCH	MID-LOW	MID-HIGH
SPIN	HIGHEST	HIGH
GROOVE	SPIN TREADS	SPIN TREADS
RAW FACE	YES	YES
FULL FACE SCORING LINES	54°, 56°, 58°, 60°	N/A

DRIVER/WY SHAFTS

HYBRID SHAFTS

IRON SHAFTS

WEDGES

PUTTERS

SWING GRIPS

PUTTER GRIPS

BUILD

JUNIOR



BUILD INFO



DRIVER	LOFT SLEEVE ADJUSTMENTS		
	LOFT	FACE ANGLE	LIE
<i>Qi4D_{LS}</i>	+/- 2°	+/- 4°	54°-58°
<i>Qi4D</i>	+/- 2°	+/- 4°	56°-60°
<i>Qi4D_{MAX}</i>	+/- 2°	+/- 4°	58°-62°
<i>Qi4D_{MAX LITE}</i>	+/- 2°	+/- 4°	58°-62°

FAIRWAY	LOFT SLEEVE ADJUSTMENTS					
	LOFT	FACE ANGLE	3 WOOD LIE	5 WOOD LIE	7 WOOD LIE	9 WOOD LIE
<i>Qi4D_{TOUR}</i>	+/- 2°	+/- 4°	57°-61°	57.5°-61.5°	58°-62°	N/A
<i>Qi4D</i>	+/- 2°	+/- 4°	57°-61°	57.5°-61.5°	58°-62°	58°-62°
<i>Qi4D_{MAX}</i>	+/- 2°	+/- 4°	57°-61°	57.5°-61.5°	N/A	N/A
<i>Qi4D_{MAX LITE}</i>	+/- 2°	+/- 4°	57°-61°	57.5°-61.5°	N/A	N/A

RESCUE	LOFT SLEEVE ADJUSTMENTS					
	LOFT	FACE ANGLE	2 RESCUE LIE	3 RESCUE LIE	4 RESCUE LIE	5 RESCUE LIE
<i>Qi4D</i>	+/- 1.5°	+/- 3°	56°-60°	56.5°-60.5°	57°-61°	57.5°-61.5°

UTILITY	LOFT ADJUSTMENTS	LIE ADJUSTMENTS	TIP	STOCK LENGTHS	CUSTOM LENGTHS
P·DHY	2° +/-	2° +/-	0.355 (TAPER TIP)	TRADITIONAL	TRADITIONAL
P·UDI	2° +/-	2° +/-	0.355 (TAPER TIP)	TRADITIONAL	TRADITIONAL

DRIVER/WOOD SHAFTS

HYBRID SHAFTS

IRON SHAFTS

WEDGES

PUTTERS

SWING GRIPS

PUTTER GRIPS

BUILD

JUNIOR



BUILD INFO



IRONS	LOFT ADJUSTMENTS	LIE ADJUSTMENTS	TIP	STOCK LENGTHS	CUSTOM LENGTHS
Qi MAX IRONS	2° +/-	4° +/-	0.370 (PARALLEL)	PROGRESSIVE	PROGRESSIVE
Qi MAX HI IRONS	2° +/-	4° +/-	0.370 (PARALLEL)	PROGRESSIVE	PROGRESSIVE
P·790	2° +/-	4° +/-	0.355 (TAPER)	TRADITIONAL	TRADITIONAL
P·770	2° +/-	4° +/-	0.355 (TAPER)	TRADITIONAL	TRADITIONAL
P·7CB	2° +/-	4° +/-	0.355 (TAPER)	TRADITIONAL	TRADITIONAL
P·7MB	2° +/-	4° +/-	0.355 (TAPER)	TRADITIONAL	TRADITIONAL
P·7TW	2° +/-	4° +/-	0.355 (TAPER)	TRADITIONAL	TRADITIONAL

WEDGES	LOFT ADJUSTMENTS	LIE ADJUSTMENTS	TIP
GS MILLED GRIND 5	2° +/-	4° +/-	0.355 (TAPER)
GS MILLED GRIND 5 TIGER WOODS SPECIAL EDITION GRIND	2° +/-	4° +/-	0.355 (TAPER)
HI-TOE ⁴	2° +/-	4° +/-	0.355 (TAPER)

PUTTERS	LOFT ADJUSTMENTS	LIE ADJUSTMENTS
Spider TOUR SERIES	2° +/-	3° +/-

DRIVER/WY SHAFTS

HYBRID SHAFTS

IRON SHAFTS

WEDGES

PUTTERS

SWING GRIPS

PUTTER GRIPS

BUILD

JUNIOR



PROGRESSIVE VS. TRADITIONAL LENGTH IRONS

IRON LENGTH NOTIFICATION

Starting in 2009, TaylorMade has offered 2 different lengths of irons referred to as Progressive Length & Traditional Length. Each length is designed to offer the best performance for a given iron design. The Progressive length is only offered in Qi/QiHL irons. Traditional lengths are used in all player iron offerings, such as our P•700 Series irons.

WHAT IS THE DIFFERENCE BETWEEN THE LENGTHS OF IRONS?

See below the actual lengths of an iron built at Progressive and Traditional specifications.

	4 IRON	5 IRON	6 IRON	7 IRON	8 IRON	9 IRON	PW	AW	SW	LW
Progressive	39.13"	38.50"	37.88"	37.25"	36.75"	36.25"	35.75"	35.50"	35.25"	35.00"
Traditional	38.50"	38.00"	37.50"	37.00"	36.50"	36.00"	35.75"	35.50"	35.25"	35.00"

WHAT IS THE BENEFIT OF PROGRESSIVE LENGTHS?

Progressive lengths offer golfers improved distance and gapping.

WHAT IS AVAILABLE IN PROGRESSIVE AND TRADITIONAL LENGTHS?

Qi / QiHL		P•SERIES	
Progressive Length	Traditional Length	Progressive Length	Traditional Length
All Stock and Custom Shafts	Not Available	Not Available	All Stock and Custom Shafts

GAME IMPROVEMENT IRON LENGTH CHANGE NOTIFICATION

TAYLORMADE GOLF COMPANY CUSTOM DEPARTMENT NOTICE REGARDING LENGTH MEASUREMENT

ATTENTION CUSTOM FITTERS AND ACCOUNTS!

As of 11/1/18, TaylorMade has improved the way we measure and list the overall club length for our iron products. In the past, we measured overall club length using a method referred to as the “pin length.” Moving forward, we will be using the measurement method known as “ground plane.” The ground plane method is the closest method to an industry standard and is the preferred measurement method of the USGA. Our goal is to simplify the club-length measurement process and improve build accuracy by switching to the preferred USGA ruler. Now matching a customer’s existing club length will be easier than ever!

NEW GROUND PLANE MEASUREMENT METHOD

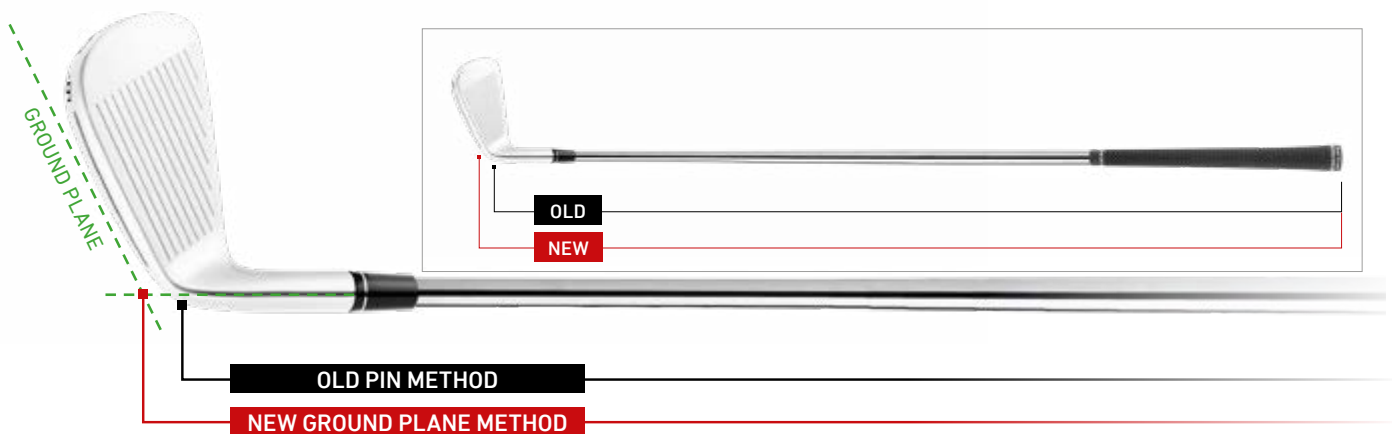

WHAT YOU NEED TO KNOW...

- Our lengths have changed slightly for the past game improvement irons (SIM2 MAX, SIM2 MAX OS, SIM MAX, SIM MAX OS, M6, M5).
- When compared to the specified club length of previous game improvement irons (STEALTH, SIM2 MAX, SIM2 MAX OS, SIM MAX, SIM MAX OS, M6, M5) appear longer in the specification table but are actually VERY similar in length to previous product (see below).
- Iron lengths are within 1/8” or less of the previous models.
- In order to keep the physical club lengths as close as possible to previous models, we rounded lengths to the nearest 1/8”. This required some irons to get slightly longer and others to get slightly shorter.

See below a table for reference. This shows the current and prior game improvement iron lengths if they were all measured on the new Ground Plane. As you can see the prior M Series Irons are within 1/8” of the physical lengths of the SIM MAX, SIM MAX OS, M6 & M5 irons.

		4	5	6	7	8	9	PW	AW
Prior M Series Product	M3, M4, MCGB Max	38.65	38.03	37.39	36.97	36.43	35.95	35.91	35.84
Latest Game Improvement Product	Qi MAX, Qi MAX HL, Qi, QiHL, SIM2 MAX, SIM2 MAX OS, SIM MAX, SIM MAX OS, M6, M5	39.13	38.50	37.88	37.25	36.75	36.25	35.75	35.50

Now that we are matching the USGA method of measurement the fitting process will be easier than ever. Rest assured this will help the accuracy of orders and custom builds moving forward. If you have any questions about this change or how to get your custom order best fit for you, please do not hesitate to call our customer service team at 1-800-888-CLUB!

P•SERIES LENGTH CHANGE NOTIFICATION

TAYLORMADE GOLF COMPANY CUSTOM DEPARTMENT NOTICE REGARDING LENGTH MEASUREMENT

ATTENTION CUSTOM FITTERS AND ACCOUNTS!

As of 11/1/18, TaylorMade has improved the way we measure and list the overall club length for our iron products. In the past, we measured overall club length using a method referred to as the “pin length.” Moving forward, we will be using the measurement method known as “ground plane.” The ground plane method is the closest method to an industry standard and is the preferred measurement method of the USGA. Our goal is to simplify the club-length measurement process and improve build accuracy by switching to the preferred USGA ruler. Now matching a customer’s existing club length will be easier than ever!

NEW GROUND PLANE MEASUREMENT METHOD

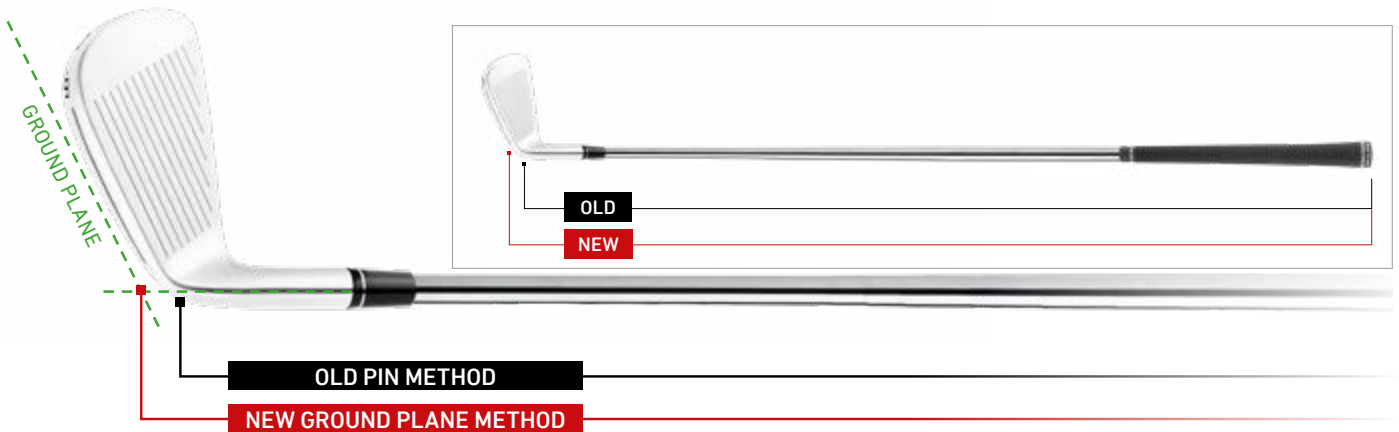

WHAT YOU NEED TO KNOW...

- Our lengths are changing slightly for latest P•Series Product (P7TW, P7MB, P7MC, P770, P790).
- When compared to the specified club length of previous P•700 series irons the new lengths appear longer, however the physical lengths are slightly shorter (see below).
- Iron lengths are within 1/8” of the previous model (AW is 1/2” different as we want the align the length with the new wedge lengths).
- We have updated our graphite shaft lengths to be the same as the steel shaft builds. This effectively makes graphite shaft club lengths 1/4” shorter than the previous generation.

See below a table for reference. This shows the current and prior P•Series iron lengths if they were all measured on the new Ground Plane. As you can see the prior P•Series Irons are 1/4” longer or less than the previous generation. (+.5” in the AW).

		3	4	5	6	7	8	9	PW	AW
Prior P•Series Models	P730, P750, P770, P790	39.13	38.63	38.13	37.63	37.13	36.63	36.13	36.00	36.00
Current P•Series Models	P7TW, P7MB, P7CB, P770, P790	39.00	38.50	38.00	37.50	37.00	36.50	36.00	35.75	35.50

HOW DO I ORDER NEW IRONS?

- If you were fit for a new iron, perfect! You don’t need to do anything except order what you were fit for.
- If you are trying to match the length of a previous P•Series set, we would recommend adjusting your club’s length by +1/4” to prevent your new irons from coming in shorter than your current build specifications.

Now that we are matching the USGA method of measurement the fitting process will be easier than ever. Rest assured this will help the accuracy of orders and custom builds moving forward. If you have any questions about this change or how to get your custom order best fit for you, please do not hesitate to call our customer service team at 1-800-888-CLUB!

WEDGE LENGTH CHANGE NOTIFICATION

TAYLORMADE GOLF COMPANY CUSTOM DEPARTMENT NOTICE REGARDING LENGTH MEASUREMENT

ATTENTION CUSTOM FITTERS AND ACCOUNTS!

As of 9/6/2019 TaylorMade has improved the way we measure the overall club length for our wedges. In November of 2018 we changed the measurement method to a 60° ground plane and we wanted to do the same for the wedges. This is in effort to continue to simplify the clubs-length measurement process and build so all products are measured the same way.

NEW GROUND PLANE MEASUREMENT METHOD

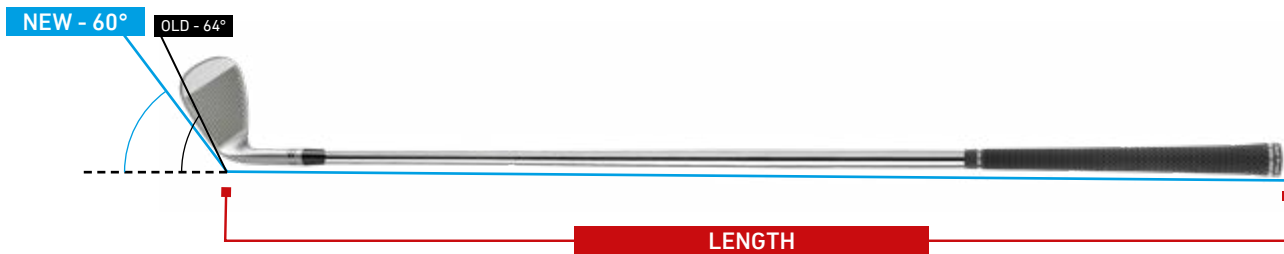

WHAT YOU NEED TO KNOW...

- The length of our new wedges would seem to be the same length as they have been in the past on paper however due to the measurement change previous wedge models are in fact +1/8" longer.
- Not all wedges have been converted over to the new measurement method. See below for details.

WEDGE	LENGTH
MG5	New Std
MG4	New Std
MG3	New Std
MG2	New Std
Hi-Toe 4	New Std
Hi-Toe RAW	New Std
Hi-Toe Bigfoot	New Std
Hi-Toe	Old std (+1/8" longer)
MG 1	Old std (+1/8" longer)

HOW DO I ORDER NEW WEDGES?

- If you were fit for your new wedges, perfect. You don't need to do anything except order what you were fit for
- If you are trying to match the length of a previous TaylorMade Wedge, we would recommend adjusting your club's length by +1/4" to prevent your new irons from coming in shorter than your current build specifications.

Now that we are matching the USGA method of measurement the fitting process will be easier than ever. Rest assured this will help the accuracy of orders and custom builds moving forward. If you have any questions about this change or how to get your custom order best fit for you, please do not hesitate to call our customer service team at 1-800-888-CLUB!

LAUNCH & SPIN

The final keys to helping a golfer gain more distance is through optimizing their launch conditions – Launch Angle and Spin Rate. To maximize distance for the golfer, the fitter should be trying to provide the highest degree of launch with the lowest spin achievable at their ball speed.

The table below shows a range of optimum launch conditions to maximize distance at varying speeds.

OPTIMIZATION CHART - DRIVER		
Ball Speed (Mph)	Launch Angle (°)	Spin (rpm)
185	10 - 14	2150 - 2800
180	10 - 14	2150 - 2800
175	10.5 - 14.5	2150 - 2850
170	10.5 - 14.5	2150 - 2850
165	10.5 - 14.5	2150 - 2850
160	11 - 15	2200 - 2850
155	11.5 - 15	2250 - 2850
150	11.5 - 15	2250 - 2850
145	12 - 16	2300 - 2900
140	12 - 16	2300 - 2900
135	12.5 - 16.5	2350 - 2950
130	12.5 - 16.5	2400 - 3000
125	13 - 17	2350 - 3050
120	13 - 17	2500 - 3100
115	13 - 17	2500 - 3100
110	13 - 17	2500 - 3100
105	13 - 17	2500 - 3100

RELATIVE LAUNCH & SPIN CONDITIONS

Fitters should also consider the swing dynamics of the golfer to understand what launch conditions are achievable. The chart below will aid fitters match up launch conditions at various swing speeds but also factoring angle of attack (AoA).

DRIVER - ANGLE OF ATTACK								
Ballspeed		-5	-3	-1	0	1	3	5
180	Launch Angle	8.5 - 10.5	9 - 11	10 - 12	10.5 - 12.5	11 - 13	11.5 - 13.5	12 - 14
	Backspin	2500 - 2900	2400 - 2800	2300 - 2700	2200 - 2600	2100 - 2500	2000 - 2400	1900 - 2300
170	Launch Angle	9 - 11	10 - 12	11 - 13	11.5 - 13.5	12 - 14	12.5 - 14.5	13 - 15
	Backspin	2600 - 3000	2500 - 2900	2400 - 2800	2300 - 2700	2200 - 2600	2100 - 2500	2000 - 2400
160	Launch Angle	10 - 12	11 - 13	11.5 - 13.5	12 - 14	13 - 15	13 - 15	14 - 16
	Backspin	2700 - 3100	2600 - 3000	2500 - 2900	2400 - 2800	2300 - 2700	2200 - 2600	2100 - 2500
150	Launch Angle	10 - 12	11 - 13	12 - 14	12.5 - 14.5	13 - 15	13 - 15	14 - 16
	Backspin	2800 - 3200	2700 - 3100	2600 - 3000	2500 - 2900	2400 - 2800	2300 - 2700	2200 - 2600
140	Launch Angle	10 - 12	11 - 13	12 - 14	12.5 - 14.5	13 - 15	14 - 16	14.5 - 16.5
	Backspin	2900 - 3300	2800 - 3200	2700 - 3100	2600 - 3000	2500 - 2900	2400 - 2800	2300 - 2700
130	Launch Angle	11 - 13	12 - 14	12.5 - 14.5	13 - 15	14 - 16	14.5 - 16.5	15 - 17
	Backspin	3000 - 3400	2900 - 3300	2800 - 3200	2700 - 3100	2600 - 3000	2500 - 2900	2400 - 2800
120	Launch Angle	12.5 - 14.5	13 - 15	13.5 - 15.5	14 - 16	14.5 - 16.5	15 - 17	15 - 17
	Backspin	3100 - 3500	3000 - 3400	2900 - 3300	2800 - 3200	2700 - 3100	2600 - 3000	2500 - 2900
110	Launch Angle	13 - 15	13.5 - 15.5	14 - 16	14.5 - 16.5	15 - 17	15 - 17	15 - 17
	Backspin	3200 - 3600	3100 - 3500	3000 - 3400	2900 - 3300	2800 - 3200	2700 - 3100	2600 - 3000
100	Launch Angle	13.5 - 15.5	14 - 16	14.5 - 16.5	14.5 - 16.5	15 - 17	15 - 17	15 - 17
	Backspin	3300 - 3700	3200 - 3600	3100 - 3500	3000 - 3400	2900 - 3300	2800 - 3200	2700 - 3100
90	Launch Angle	14 - 16	14 - 16	14.5 - 16.5	15 - 17	15 - 17	15 - 17	15 - 17
	Backspin	3400 - 3800	3300 - 3700	3200 - 3600	3100 - 3500	3000 - 3400	2900 - 3300	2800 - 3200
80	Launch Angle	14 - 16	14 - 16	14.5 - 16.5	15 - 17	15 - 17	15 - 17	15 - 17
	Backspin	3500 - 3900	3400 - 3800	3300 - 3700	3200 - 3600	3100 - 3500	3000 - 3400	2900 - 3300
70	Launch Angle	14 - 16	14 - 16	14.5 - 16.5	15 - 17	15 - 17	15 - 17	15 - 17
	Backspin	3600 - 4000	3500 - 3900	3400 - 3800	3300 - 3700	3200 - 3600	3100 - 3500	3000 - 3400

This data was created using radar-based technology. For launch monitors using optical based technology please subtract 2° from the angle of attack when referring to this table. For example: +3 on optical-based launch monitor please refer to the +1 column on the table.

IRONS						
7 IRON BALL SPEED	RANGE OF LAUNCH ANGLE	RANGE OF SPIN RATE (RPM)	EXPECTED HEAD SPEED (MPH)	EXPECTED CARRY DISTANCE (YARDS)	EXPECTED PEAK HEIGHT (YARDS)	EXPECTED LANDING ANGLE (DEGREES)
70	19.5 (21.5) 22.5	5500 (4700) 3800	51	77	10.2	32.2°
80	19.0 (20.5) 22.0	5900 (5000) 4100	58	96	13.4	34.7°
90	18.0 (19.5) 21.0	6300 (5400) 4500	66	115	17	37.6°
100	17.5 (18.5) 20.5	6800 (5800) 4900	73	134	21	40.5°
110	16.5 (18) 19.5	7100 (6200) 5200	80	151	26.2	43.9°
120	15.5 (17) 18.5	7300 (6600) 5700	88	167	30.9	46.4°
130	14.5 (16) 18.0	7900 (7000) 6000	95	181	35.8	48.7°
140	13.5 (15.5) 17.0	8100 (7300) 6400	102	195	41.7	50.9°

Higher launch and lower spin moves generally along landing angle lines. Higher launch and higher spin will increase landing angle.

DRIVER / FAIRWAY LOFT SLEEVE SETTINGS

- Each click of the 4° Loft Sleeve increases or decreases loft by 0.5 - 0.75°
- Each click of the 4° Loft Sleeve increases or decreases face angle by 1.0 – 2.0°
- Each click of the 4° Loft Sleeve increases or decreases lie angle 0.5 – 0.75°

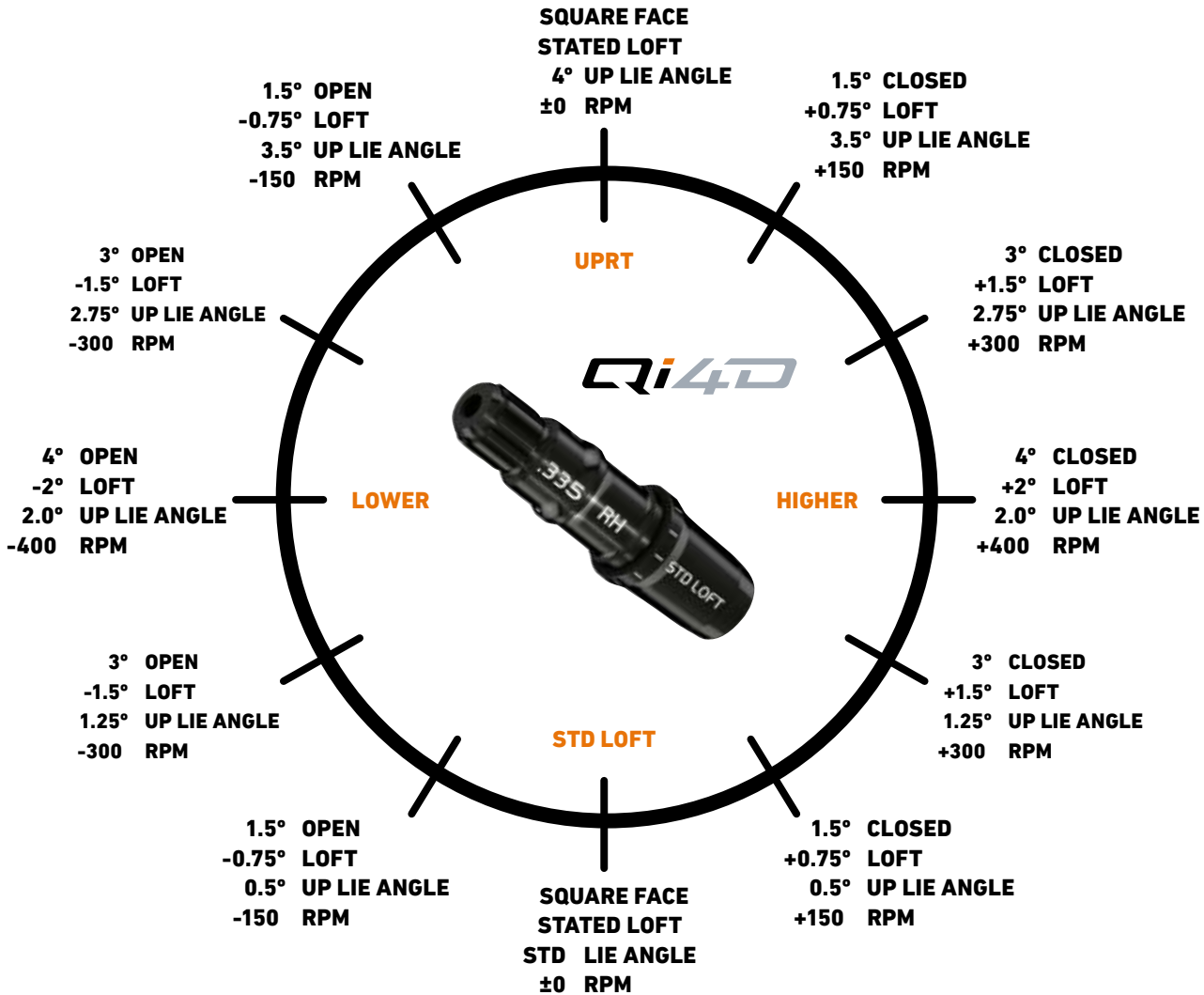

RESCUE LOFT SLEEVE SETTINGS

- Each click of the 1.5° Loft Sleeve increases or decreases loft 0.5°
- Each click of the 1.5° Loft Sleeve increases or decreases face angle 0.25° - 1°
- Each click of the 1.5° Loft Sleeve increases or decreases lie angle 0.5°

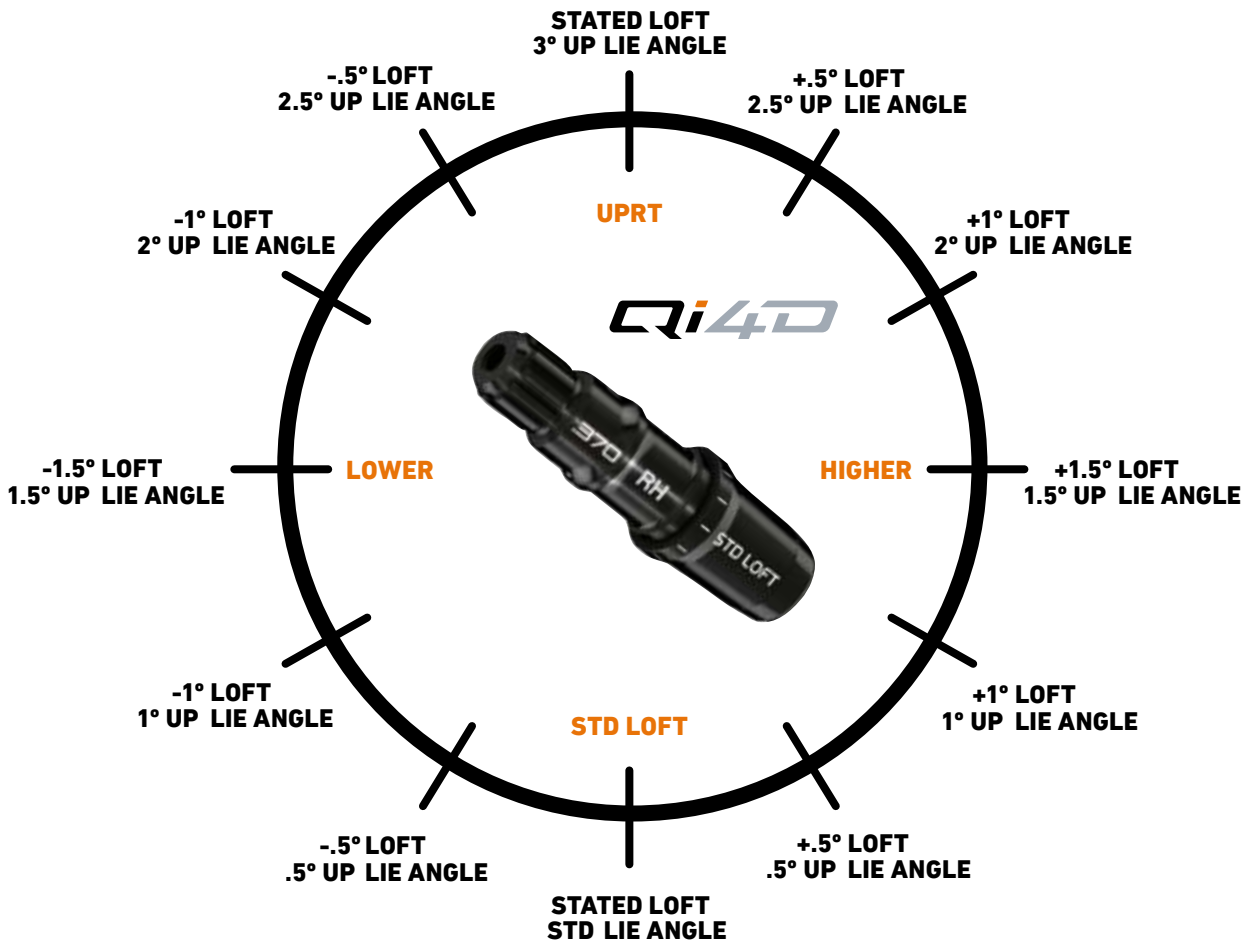

TRAJECTORY ADJUSTMENT SYSTEM (TAS)



LENGTH	REAR WEIGHT	FRONT WEIGHT
+2"	3	7
+1.5" to +1.75"	3	8
+0.75 to +1.25"	3	10
+0.5"	4	11
+0.25"	4	13
Stock	4	15
-0.25	5	15
-0.5	7	15
-0.75	10	15
-1	11	15
-1.25	13	15
-1.5 to -2"	15	15

WEIGHTS AND BALL FLIGHT CHANGES		
LOCATION	REAR WEIGHT	FRONT WEIGHT
Back	15g	4g
Mid	8g	11g
Forward (Stock Configuration)	4g	15g

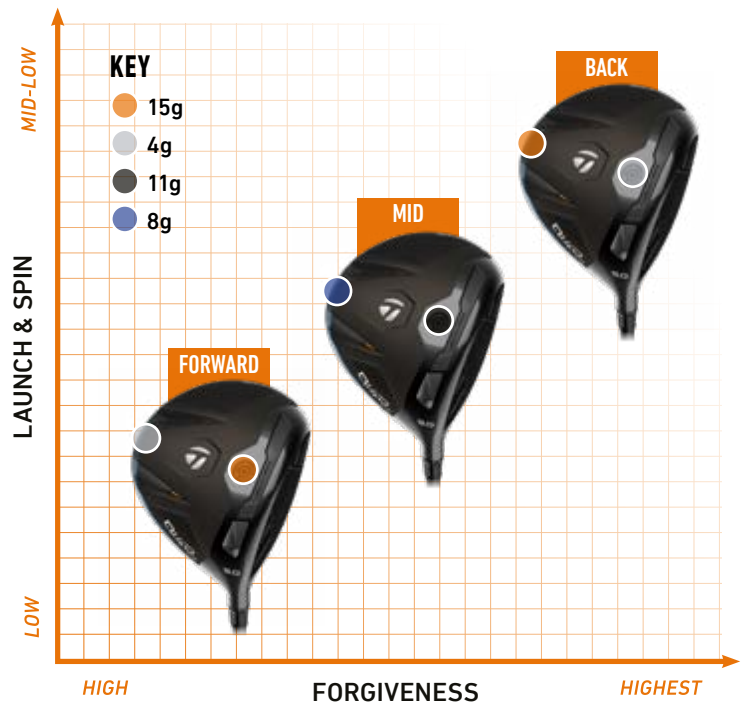

LENGTH	REAR HEEL	REAR TOE	FRONT HEEL	FRONT TOE
+1.75" to +2.0"	5	5	3	3
+0.75" to +1.5"	7	7	3	3
+0.5"	8	8	3	3
+0.25"	9	9	3	3
Stock	9	9	4	4
-0.25"	10	10	4	4
-0.5"	10	10	5	5
-0.75"	11	11	5	5
-1"	13	13	4	4
-1.25"	13	13	5	5
-1.5"	13	13	7	7
-1.75"	15	15	7	7
-2"	15	15	9	9

WEIGHTS AND BALL FLIGHT CHANGES				
LOCATION	REAR HEEL	REAR TOE	FRONT HEEL	FRONT TOE
BACK (STOCK)	9g	9g	4g	4g
MAX DRAW	9g	4g	9g	4g
DRAW	4g	9g	9g	4g
Max Fade	4g	9g	4g	9g
Fade	9g	4g	4g	9g
Front	4g	4g	9g	9g

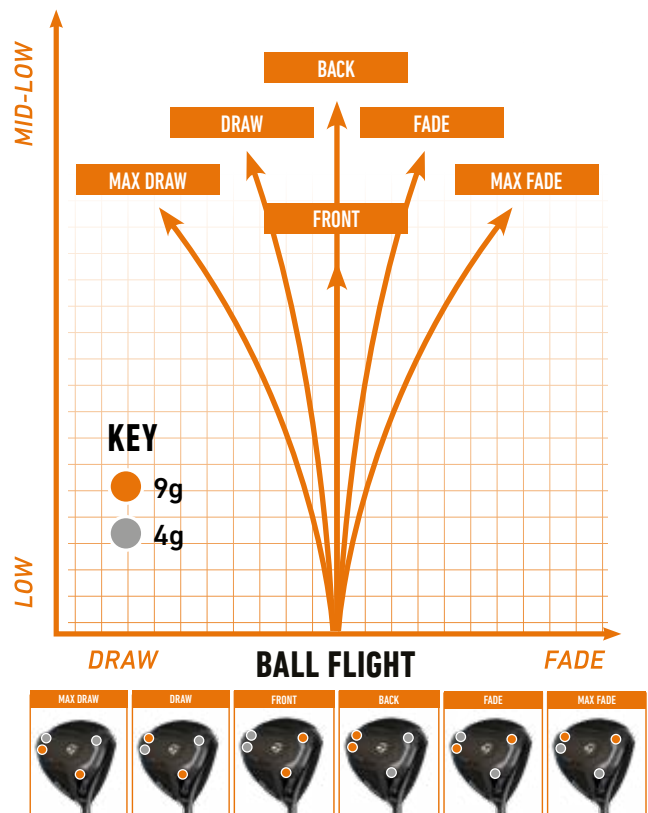

TRAJECTORY ADJUSTMENT SYSTEM (TAS)



Qi4D MAX

LENGTH	REAR WEIGHT	FRONT WEIGHT
+2"	3	3
+1.75"	5	3
+1.5"	5	3
+1.25"	7	3
+1.0"	8	3
+0.75"	9	3
+0.5"	10	3
+0.25"	11	4
Stock	13	4
-0.25"	15	5
-0.5"	15	7
-0.75"	15	10
-1"	15	11
-1.25"	15	13
-1.5 to -2"	15	15

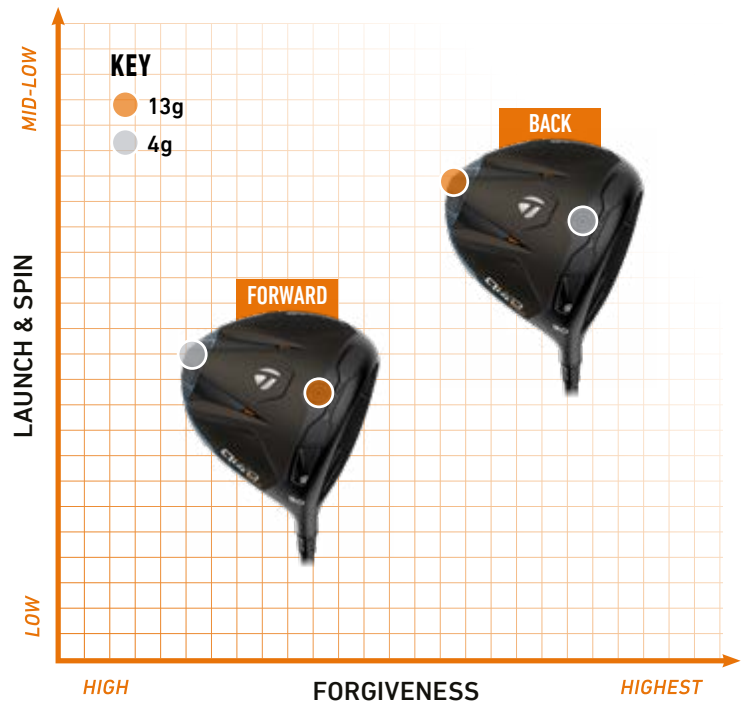

WEIGHTS AND BALL FLIGHT CHANGES

LOCATION	REAR WEIGHT	FRONT WEIGHT
BACK	13g	4g
FORWARD	4g	13g

Qi4D MAX LITE

LENGTH	FRONT WEIGHT
+0.75 to 2"	3
+0.25" to +0.5"	4
STD	4
-0.25"	7
-0.5"	8
-0.75"	10
-1"	13
-1.5" to -2"	15

KEY

- 4g



DRIVER/WY SHAFTS

HYBRID SHAFTS

IRON SHAFTS

WEDGES

PUTTERS

SWING GRIPS

PUTTER GRIPS

BUILD

JUNIOR



TAYLORMADE SWINGWEIGHT SYSTEM (TAS)



LENGTH	REAR WEIGHT	TOE WEIGHT	HEEL WEIGHT
+1.75" TO +2.0"	4	4	4
+1.5"	5	4	4
+1" TO 1.25"	8	4	4
+0.75"	9	4	4
+0.5"	11	4	4
+0.25"	13	4	4
STD	15	4	4
-0.25"	15	5	5
-0.5"	13	7	7
-0.75"	15	7	7
-1"	15	8	8
-1.25"	13	10	10
-1.5"	15	10	10
-1.75"	15	11	11
-2"	13	13	13

WEIGHTS AND BALL FLIGHT CHANGES			
LOCATION	REAR WEIGHT	TOE WEIGHT	HEEL WEIGHT
BACK (STOCK)	15g	4g	4g
MAX DRAW	4g	4g	15g
DRAW	8g	4g	8g
MAX FADE	4g	15g	4g
FADE	8g	8g	4g
FRONT	4g	8g	8g

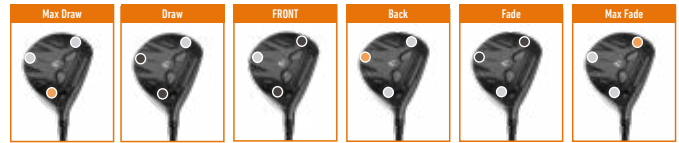
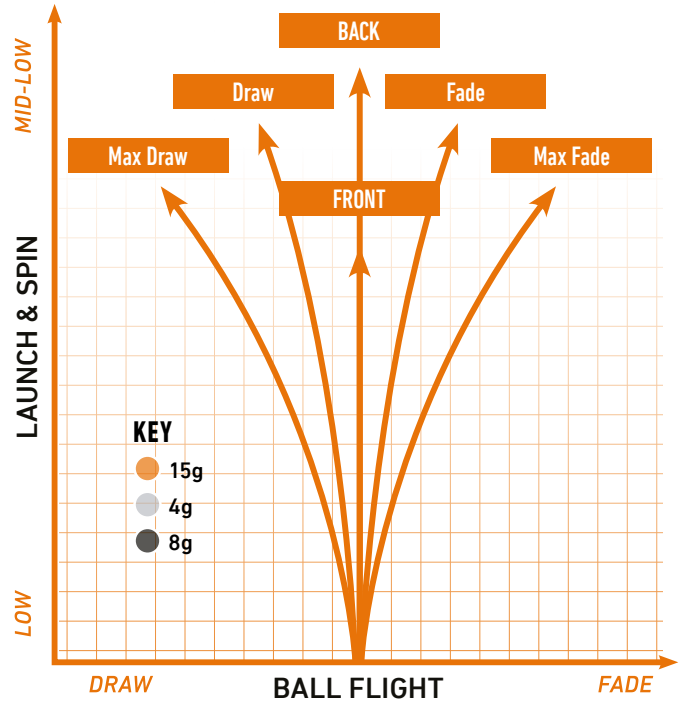

LENGTH	Qi4D & Qi4D MAX FAIRWAYS	Qi4D MAX LITE FAIRWAY	Qi4D RESCUE	Qi4D MAX RESCUE	Qi4D MAX LITE RESCUE
+2"	3	3	3	3	3
+1.75"	3	3	3	3	3
+1.5"	4	4	4	4	4
+1.25"	4	4	4	4	4
+1"	4	4	4	4	4
+0.75"	4	4	4	4	4
+0.5"	5	4	4	4	4
+0.25"	5	4	4	4	4
STD	8	4	8	8	4
-0.25"	10	7	7	7	7
-0.5"	11	9	8	8	8
-0.75"	13	11	10	10	10
-1"	15	13	13	13	13
-1.25"	15	15	15	15	15
-1.5"	15	15	15	15	15
-1.75"	15	15	15	15	15

REAX™ SHAFTS

A revolution in shaft fitting, based on 11 million shots captured over 20+ years, allows golfers to quickly identify their rotation rate and play a shaft that matches their unique swing profile. More precise shaft fitting helps golfers achieve more centered contact, increased speed, distance, and accuracy

Leveraging Mitsubishi Chemicals' industry leading material expertise and production processes allows us to offer world-class shafts for a wide range of applications and swing types.



"It's less about flight and more about what's right"

- Chandler Carr, Sr. Product Manager, Global MW

CUSTOM DRIVER / FWY SHAFT OPTIONS



AVERAGE CLUBHEAD SPEED < 72 MPH / 32 MPS

		LR LOW-ROTATION			MR MID-ROTATION			HR HIGH-ROTATION		
SMOOTH > SOFTER >									PROJ X CYPHER 40 L	
										UST HELIUM NCT 4 L
								FUJIKURA AIR SPEEDER 40 L 2025		
					MITSUBISHI VANQUISH 4 R2					
								MCA REAX MR 40 L		
								UST HELIUM NCT 5 A		
		FUJIKURA VENTUS WHITE VC-4R2	PROJ X CYPHER 40 A						FUJIKURA SPEEDER NX TCS L	
					MCA REAX MR 40 A					
				MITSUBISHI VANQUISH 4 R	FUJIKURA SPEEDER NX TCS A					
TEMPO HANDLE STIFFNESS										
< QUICK < STIFFER										
		< STIFFER			TIP STIFFNESS			SOFTER >		

DRIVER/FWY SHAFTS

HYBRID SHAFTS

IRON SHAFTS

WEDGES

PUTTERS

SWING GRIPS

PUTTER GRIPS

BUILD

JUNIOR



CUSTOM DRIVER / FWY SHAFT OPTIONS



AVERAGE CLUBHEAD SPEED 72 - 81 MPH / 32 - 35 MPS

		LR LOW-ROTATION			MR MID-ROTATION			HR HIGH-ROTATION			
SMOOTH > SOFTER >	TEMPO HANDLE STIFFNESS										
										FUJIKURA AIR SPEEDER 40 L	
									MITSUBISHI VANQUISH 4 R2		
										UST HELIUM NCT 5 A	
< QUICK < STIFFER	TEMPO HANDLE STIFFNESS										
		< STIFFER			TIP STIFFNESS			SOFTER >			

DRIVER/FWY SHAFTS

HYBRID SHAFTS

IRON SHAFTS

WEDGES

PUTTERS

SWING GRIPS

PUTTER GRIPS

BUILD

JUNIOR



CUSTOM DRIVER / FWY SHAFT OPTIONS



AVERAGE CLUBHEAD SPEED 82 - 92 MPH / 36 - 40 MPS

		LR LOW-ROTATION			MR MID-ROTATION			HR HIGH-ROTATION			
SMOOTH > SOFTER >									MITSUBISHI DIAMANA BB 43 A		
										FUJIKURA AIR SPEEDER 50 A	
								FUJIKURA VENTUS RED VC+ 5 R2			
					ARETERA A02 BLUE 55-3			FUJIKURA VENTUS RED VC 5 R2			
					ARETERA A02 GRAY 55-3	FUJIKURA VENTUS TR BLUE 5 R				MITSUBISHI VANQUISH 5 R	
		FUJIKURA VENTUS BLUE VC+ 5 R							FUJIKURA SPEEDER NX TCS S		
									RETERA EC1 BLUE 55-3	MCA REAX HR 50 R	
									UST PROFORCE V2 6 R		
						FUJIKURA VENTUS BLUE 2025 R	MCA REAX MR 50 R	PROJ X CYPHER 50 S		FUJIKURA AIR SPEEDER 50 R	UST HELIUM NCT 5 S
								FUJIKURA VENTUS WHITE VC+ 4 S			
TEMPO HANDLE STIFFNESS											
< QUICK < STIFFER											
		< STIFFER			TIP STIFFNESS			SOFTER >			

DRIVER/FWY SHAFTS

HYBRID SHAFTS

IRON SHAFTS

WEDGES

PUTTERS

SWING GRIPS

PUTTER GRIPS

BUILD

JUNIOR



CUSTOM DRIVER / FWY SHAFT OPTIONS



AVERAGE CLUBHEAD SPEED 103 - 109 MPH / 46 - 48 MPS

		LR LOW-ROTATION			MR MID-ROTATION			HR HIGH-ROTATION				
SMOOTH > SOFTER >									FUJIKURA VENTUS TR BLUE VC 5 S		FUJIKURA VENTUS BLACK VC+ 5 S	
										FUJIKURA VENTUS BLUE VC+ 6 S		
								FUJIKURA VENTUS BLACK VC+ 5 X				
									GD TOUR AD VF 6 S			
										ARETERA A02 GRAY 65-4	MITSUBISHI KAILI WHITE DW 60 S	
									FUJIKURA VENTUS BLUE VC+ 5 X	MITSUBISHI KAILI BLUE CB DW 60 X	PROJ X HZRDUS BLACK G5 60 X	
									MITSUBISHI KAILI WHITE DW 70 S	FUJIKURA VENTUS BLUE VC 6 S		
										MCA REAX HR 50 X		
										PROJ X HZRDUS BLACK G5 70 X		
TEMPO HANDLE STIFFNESS												
< QUICK < STIFFER												

DRIVER/FWY SHAFTS

HYBRID SHAFTS

IRON SHAFTS

WEDGES

PUTTERS

SWING GRIPS

PUTTER GRIPS

BUILD

JUNIOR



CUSTOM DRIVER / FWY SHAFT OPTIONS



AVERAGE CLUBHEAD SPEED 110+ MPH / 49+ MPS

		LR LOW-ROTATION			MR MID-ROTATION			HR HIGH-ROTATION				
SMOOTH > SOFTER >												
							ARETERA A02 GRAY 65-5		FUJIKURA VENTUS BLACK VC+ 6 S	mitsubishi tensei 1k black 65 s		
								FUJIKURA VENTUS BLACK VC 6 S	mitsubishi tensei 1k black 75 s	FUJIKURA VENTUS BLUE VC 6 S		
										FUJIKURA VENTUS BLUE VC 7 S		
										GD TOUR AD VF 7 S		
											FUJIKURA VENTUS TR BLUE VC 6 S	
												FUJIKURA VENTUS TR BLUE VC 6 S
												FUJIKURA VENTUS TR BLUE VC 6 S
												FUJIKURA VENTUS TR BLUE VC 6 S
												FUJIKURA VENTUS TR BLUE VC 6 S
TEMPO HANDLE STIFFNESS												
< QUICK < STIFFER												
		< STIFFER			TIP STIFFNESS			SOFTER >				

DRIVER/FWY SHAFTS

HYBRID SHAFTS

IRON SHAFTS

WEDGES

PUTTERS

SWING GRIPS

PUTTER GRIPS

BUILD

JUNIOR



CUSTOM DRIVER / FWY SHAFT OPTIONS



TaylorMade will continue to offer drivers lengths of +1.75 inches, which may exceed the total 46 inch limit as defined by the USGA. Please be aware of this during your fitting sessions. If a golfer intends to purchase and use such a driver in a sanctioned competition, please alert them to the fact that it may not meet the conforming standards as defined by the USGA's Model Local Rule G-10: "In making a stroke, the player must not use a club, except for a putter, which exceeds 46 inches in length.

Advise golfers purchasing drivers at +1.75 to check local rules and/or measure their driver from the end of the grip to assure conformity prior to competing. Variables that can contribute to deviations in length measurements include grip size and/or the presence of a grip cap, such as a tracking tool.

A NOTE ON DRIVER ROTATION COLUMN

These shafts may not match the color designation to the rotation group because we measure them blindly. We selected the clubhead speed group to match the flex designation on the shaft and that is the designated rotation listed for the MW shafts.

TM | MCA



MODEL	FLEX	WEIGHT	TORQUE	TIP SIZE	DR ROTATION	MAX/MIN CUSTOM LENGTH	UPCHARGE
REAX 60 LR	X	65g	3.5	0.335	LR	+1.75" / -2"	\$-
REAX 60 LR	S	65g	3.9	0.335	LR	+1.75" / -2"	\$-
REAX 60 LR	R	60g	4.2	0.335	LR	+1.75" / -2"	\$-



MODEL	FLEX	WEIGHT	TORQUE	TIP SIZE	DR ROTATION	MAX/MIN CUSTOM LENGTH	UPCHARGE
REAX 50 MR	X	56g	4.4	0.335	MR	+5" / -2"	\$-
REAX 50 MR	S	53g	4.4	0.335	MR	+5" / -2"	\$-
REAX 50 MR	R	52g	4.6	0.335	MR	+5" / -2"	\$-
REAX 50 MR	A	51g	4.6	0.335	MR	+5" / -2"	\$-
REAX 60 MR	X	63g	4.3	0.335	MR	+5" / -2"	\$-
REAX 60 MR	S	63g	4.5	0.335	MR	+1.75" / -2"	\$-
REAX 60 MR	R	63g	4.7	0.335	MR	+5" / -2"	\$-



MODEL	FLEX	WEIGHT	TORQUE	TIP SIZE	DR ROTATION	MAX/MIN CUSTOM LENGTH	UPCHARGE
REAX 50 HR	X	59g	4.1	0.335	HR	+1.75" / -2"	\$-
REAX 50 HR	S	59g	4.6	0.335	HR	+1.75" / -2"	\$-
REAX 50 HR	R	57g	4.7	0.335	HR	+1.75" / -2"	\$-
REAX 50 HR	A	51g	5.5	0.335	HR	+1.75" / -2"	\$-
REAX 60 HR	X	67g	4.3	0.335	HR	+1.75" / -2"	\$-
REAX 60 HR	S	67g	4.6	0.335	HR	+5" / -2"	\$-
REAX 60 HR	R	65g	4.7	0.335	HR	+1.75" / -2"	\$-

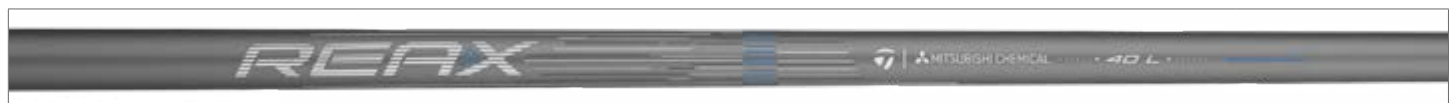

MODEL	FLEX	WEIGHT	TORQUE	TIP SIZE	DR ROTATION	MAX/MIN CUSTOM LENGTH	UPCHARGE
REAX 40 MR	R	44g	6.7		MR	+1" / -2"	\$-
REAX 40 MR	A	43g	6.8		MR	+1" / -2"	\$-
REAX 40 MR	L	42g	6.9		MR	+1" / -2"	\$-

CUSTOM DRIVER / FWY SHAFT OPTIONS



TM | MCA

MODEL	FLEX	WEIGHT	TORQUE	TIP SIZE	DR ROTATION	MAX/MIN CUSTOM LENGTH	UPCHARGE
REAX 75 FW (Qi4D Tour FW)	X	77g	3.5	0.335	N/A	+2" / -2"	\$-
REAX 75 FW (Qi4D Tour FW)	S	75g	3.9	0.335	N/A	+2" / -2"	\$-

MODEL	FLEX	WEIGHT	TORQUE	TIP SIZE	DR ROTATION	MAX/MIN CUSTOM LENGTH	UPCHARGE
REAX 65 FW	R	63g	4.2	0.335	N/A	+2" / -2"	\$-
REAX 65 FW (Qi4D FW)	X	64g	4.3	0.335	N/A	+2" / -2"	\$-
REAX 65 FW (Qi4D FW)	S	63g	4.4	0.335	N/A	+2" / -2"	\$-

MODEL	FLEX	WEIGHT	TORQUE	TIP SIZE	DR ROTATION	MAX/MIN CUSTOM LENGTH	UPCHARGE
REAX 55 FW (Qi4D FW and MAX FW)	R	52g	3.7	0.335	N/A	+2" / -2"	\$-
REAX 55 FW (Qi4D FW and MAX FW)	A	51g	3.7	0.335	N/A	+2" / -2"	\$-
REAX 55 FW (Qi4D MAX FW)	S	54g	3.7	0.335	N/A	+2" / -2"	\$-

MODEL	FLEX	WEIGHT	TORQUE	TIP SIZE	DR ROTATION	MAX/MIN CUSTOM LENGTH	UPCHARGE
REAX 45 FW (Qi4D MAX LITE FW)	R	49g	5.3	0.335	N/A	+2" / -2"	\$-
REAX 45 FW (Qi4D MAX LITE FW)	A	45g	6.7	0.335	N/A	+2" / -2"	\$-

MODEL	FLEX	WEIGHT	TORQUE	TIP SIZE	DR ROTATION	MAX/MIN CUSTOM LENGTH	UPCHARGE
REAX 40 FW (Qi4D MAX LITE FW)	L	43g	6.8	0.335	N/A	+2" / -2"	\$-

DRIVER/FWY SHAFTS

HYBRID SHAFTS

IRON SHAFTS

WEDGES

PUTTERS

SWING GRIPS

PUTTER GRIPS

BUILD

JUNIOR



CUSTOM DRIVER / FWY SHAFT OPTIONS



ACCRA



MODEL	FLEX	WEIGHT	TORQUE	TIP SIZE	DR ROTATION	MAX/MIN CUSTOM LENGTH	UPCHARGE
ACCRA TZ5 65	X (M5)	62g	3.5	0.335	LR▲	+2" / -2"	\$250.00
ACCRA TZ5 65	S (M4)	61g	3.5	0.335	LR▲	+2" / -2"	\$250.00
ACCRA TZ5 75	X (M5)	71g	3.2	0.335	LR▲	+2" / -2"	\$250.00
ACCRA TZ5 75	S (M4)	70g	3.2	0.335	LR▲	+2" / -2"	\$250.00



MODEL	FLEX	WEIGHT	TORQUE	TIP SIZE	DR ROTATION	MAX/MIN CUSTOM LENGTH	UPCHARGE
ACCRA TZ6 65	X (M5)	58g	2.5	0.335	MR▲	+2" / -2"	\$250.00
ACCRA TZ6 65	S (M4)	56g	2.5	0.335	HR▲	+2" / -2"	\$250.00
ACCRA TZ6 75	X (M5)	72g	2.3	0.335	MR▲	+2" / -2"	\$250.00
ACCRA TZ6 75	S (M4)	71g	2.3	0.335	MR▲	+2" / -2"	\$250.00

ALDILA



MODEL	FLEX	WEIGHT	TORQUE	TIP SIZE	DR ROTATION	MAX/MIN CUSTOM LENGTH	UPCHARGE
ASCENT LADIES	L	47g	5.9	0.335	HR▲	+1.75" / -2"	\$-

DRIVER/FWY SHAFTS

HYBRID SHAFTS

IRON SHAFTS

WEDGES

PUTTERS

SWING GRIPS

PUTTER GRIPS

BUILD

JUNIOR



CUSTOM DRIVER / FWY SHAFT OPTIONS



ARETERA



MODEL	FLEX	WEIGHT	TORQUE	DR ROTATION	MAX/MIN CUSTOM LENGTH	UPCHARGE
EC1 BLUE 45	2-A	48g	4.4	HR△	+1.75" / -2"	\$320.00
EC1 BLUE 55	2-A	58g	4.2	HR△	+1.75" / -2"	\$320.00
EC1 BLUE 55	3-R	58g	4	HR△	+1.75" / -2"	\$320.00
EC1 BLUE 65	4-S	58g	3.8	MR△	+1.75" / -2"	\$320.00



MODEL	FLEX	WEIGHT	TORQUE	TIP SIZE	DR ROTATION	MAX/MIN CUSTOM LENGTH	UPCHARGE
EC1 GRAY 55	3-R	58g	4	0.335	MR△	+2" / -2"	\$320.00
EC1 GRAY 65	4-S	69g	3.4	0.335	MR△	+2" / -2"	\$320.00
EC1 GRAY 65	5-X	69g	3.4	0.335	HR△	+2" / -2"	\$320.00
EC1 GRAY 75	5-X	78g	3.2	0.335	MR△	+2" / -2"	\$320.00



MODEL	FLEX	WEIGHT	TORQUE	TIP SIZE	DR ROTATION	MAX/MIN CUSTOM LENGTH	UPCHARGE
A02 BLUE 55	3-R	57.5g	3.9	0.335	LR△	+2" / -2"	\$420.00
A02 BLUE 65	4-S	65.5g	3.5	0.335	LR△	+2" / -2"	\$420.00
A02 BLUE 65	5-X	66g	3.3	0.335	MR△	+2" / -2"	\$420.00
A02 BLUE 75	5-X	78g	3.1	0.335	LR△	+2" / -2"	\$420.00



MODEL	FLEX	WEIGHT	TORQUE	TIP SIZE	DR ROTATION	MAX/MIN CUSTOM LENGTH	UPCHARGE
A02 GRAY 55	3-R	57.5g	3.9	0.335	MR△	+2" / -2"	\$420.00
A02 GRAY 65	4-S	65.5g	3.5	0.335	LR△	+2" / -2"	\$420.00
A02 GRAY 65	5-X	66g	3.3	0.335	MR△	+2" / -2"	\$420.00
A02 GRAY 75	5-X	78g	3.1	0.335	LR△	+2" / -2"	\$420.00

DRIVER/FWY SHAFTS

HYBRID SHAFTS

IRON SHAFTS

WEDGES

PUTTERS

SWING GRIPS

PUTTER GRIPS

BUILD

JUNIOR



CUSTOM DRIVER / FWY SHAFT OPTIONS



FUJIKURA



MODEL	FLEX	WEIGHT	TORQUE	DR ROTATION	MAX/MIN CUSTOM LENGTH	UPCHARGE
SPEEDER MD 6	X	62g	4.3	MR△	+1.75" / -2"	\$0.00
SPEEDER MD 6	S	58g	4.4	MR△	+1.75" / -2"	\$0.00
SPEEDER MD 5	R	52g	4.5	MR△	+1.75" / -2"	\$0.00



MODEL	FLEX	WEIGHT	TORQUE	TIP SIZE	DR ROTATION	MAX/MIN CUSTOM LENGTH	UPCHARGE
VENTUS BLUE w/ VELOCORE+ 5	R	58.5g	3.7	0.335	LR△	+2" / -2"	\$350.00
VENTUS BLUE w/ VELOCORE+ 5	S	58.5g	3.5	0.335	LR△	+2" / -2"	\$350.00
VENTUS BLUE w/ VELOCORE+ 5	X	59g	3.3	0.335	MR△	+2" / -2"	\$350.00
VENTUS BLUE w/ VELOCORE+ 6	S	65.5g	3.3	0.335	HR△	+2" / -2"	\$350.00
VENTUS BLUE w/ VELOCORE+ 6	X	66g	3.1	0.335	MR△	+2" / -2"	\$350.00
VENTUS BLUE w/ VELOCORE+ 7	S	76g	3.0	0.335	HR△	+2" / -2"	\$350.00
VENTUS BLUE w/ VELOCORE+ 7	X	77g	2.9	0.335	MR△	+2" / -2"	\$350.00



MODEL	FLEX	WEIGHT	TORQUE	TIP SIZE	DR ROTATION	MAX/MIN CUSTOM LENGTH	UPCHARGE
VENTUS RED W/ VELOCORE + 5	A	59g	3.8	0.335	MR△	+2" / -2"	\$350.00
VENTUS RED W/ VELOCORE + 5	R	59.5g	3.6	0.335	MR△	+2" / -2"	\$350.00
VENTUS RED W/ VELOCORE + 5	S	59.5g	3.4	0.335	MR△	+2" / -2"	\$350.00
VENTUS RED W/ VELOCORE + 6	S	67.5g	3.3	0.335	HR△	+2" / -2"	\$350.00
VENTUS RED W/ VELOCORE + 6	X	67.5g	3.2	0.335	HR△	+2" / -2"	\$350.00
VENTUS RED W/ VELOCORE + 7	S	77.5g	3.1	0.335	HR△	+2" / -2"	\$350.00
VENTUS RED W/ VELOCORE + 7	X	78g	3.0	0.335	HR△	+2" / -2"	\$350.00
VENTUS RED W/ VELOCORE + 8	X	86.5g	2.8	0.335	HR△	+2" / -2"	\$350.00



MODEL	FLEX	WEIGHT	TORQUE	TIP SIZE	DR ROTATION	MAX/MIN CUSTOM LENGTH	UPCHARGE
VENTUS TR RED w/ VELOCORE 6	X	69.5g	3	0.335	HR△	+2" / -2"	\$350.00
VENTUS TR RED w/ VELOCORE 6	S	68g	3.2	0.335	HR△	+2" / -2"	\$350.00
VENTUS TR RED w/ VELOCORE 7	X	78g	2.8	0.335	MR△	+2" / -2"	\$350.00
VENTUS TR RED w/ VELOCORE 7	S	77g	3	0.335	MR△	+2" / -2"	\$350.00

CUSTOM DRIVER / FWY SHAFT OPTIONS



FUJIKURA



MODEL	FLEX	WEIGHT	TORQUE	TIP SIZE	DR ROTATION	MAX/MIN CUSTOM LENGTH	UPCHARGE
VENTUS BLACK w/ VELOCORE+ 5	S	59.5g	3.5	0.335	LR△	+2" / -2"	\$350.00
VENTUS BLACK w/ VELOCORE+ 5	X	59.5g	3.3	0.335	MR△	+2" / -2"	\$350.00
VENTUS BLACK w/ VELOCORE + 6	S	66g	3.2	0.335	MR△	+2" / -2"	\$350.00
VENTUS BLACK w/ VELOCORE + 6	X	66.5g	3	0.335	MR△	+2" / -2"	\$350.00
VENTUS BLACK w/ VELOCORE + 7	S	75g	3	0.335	MR△	+2" / -2"	\$350.00
VENTUS BLACK w/ VELOCORE + 7	X	75.5g	2.9	0.335	LR△	+2" / -2"	\$350.00
VENTUS BLACK w/ VELOCORE + 8	X	81g	2.8	0.335	LR△	+2" / -2"	\$350.00



MODEL	FLEX	WEIGHT	TORQUE	TIP SIZE	DR ROTATION	MAX/MIN CUSTOM LENGTH	UPCHARGE
VENTUS WHITE W/ VELOCORE+ 4	R2 -A	49.5g	5.0	0.335	MR△	+2" / -2"	\$350.00
VENTUS WHITE W/ VELOCORE+ 4	R	49.5g	5.0	0.335	MR△	+2" / -2"	\$350.00
VENTUS WHITE W/ VELOCORE+ 4	S	49.5g	5.0	0.335	MR△	+2" / -2"	\$350.00



MODEL	FLEX	WEIGHT	TORQUE	TIP SIZE	DR ROTATION	MAX/MIN CUSTOM LENGTH	UPCHARGE
VENTUS TR BLACK w/ VELOCORE 6	X	70g	2.9	0.335	LR△	+2" / -2"	\$350.00
VENTUS TR BLACK w/ VELOCORE 6	S	69.5g	3.1	0.335	LR△	+2" / -2"	\$350.00
VENTUS TR BLACK w/ VELOCORE 7	X	80g	2.8	0.335	LR△	+2" / -2"	\$350.00
VENTUS TR BLACK w/ VELOCORE 7	S	79.5g	2.7	0.335	LR△	+2" / -2"	\$350.00



MODEL	FLEX	WEIGHT	TORQUE	TIP SIZE	DR ROTATION	MAX/MIN CUSTOM LENGTH	UPCHARGE
VENTUS TR BLUE w/ VELOCORE 5	R	58g	3.5	0.335	MR△	+2" / -2"	\$350.00
VENTUS TR BLUE w/ VELOCORE 5	S	58g	3.3	0.335	HR△	+2" / -2"	\$350.00
VENTUS TR BLUE w/ VELOCORE 6	S	68g	3.1	0.335	MR△	+2" / -2"	\$350.00
VENTUS TR BLUE w/ VELOCORE 6	X	68g	2.9	0.335	MR△	+2" / -2"	\$350.00
VENTUS TR BLUE w/ VELOCORE 7	S	77.5g	2.9	0.335	MR△	+2" / -2"	\$350.00
VENTUS TR BLUE w/ VELOCORE 7	X	78.5g	2.7	0.335	MR△	+2" / -2"	\$350.00
VENTUS TR BLUE w/ VELOCORE 8	S	86.5g	2.8	0.335	LR△	+2" / -2"	\$350.00
VENTUS TR BLUE w/ VELOCORE 8	X	88.5g	2.6	0.335	LR△	+2" / -2"	\$350.00

CUSTOM DRIVER / FWY SHAFT OPTIONS



GRAPHITE DESIGN



MODEL	FLEX	WEIGHT	TORQUE	TIP SIZE	DR ROTATION	MAX/MIN CUSTOM LENGTH	UPCHARGE
TOUR AD IZ 5	S	56g	4.4	0.335	HR△	+2" / -2"	\$250.00
TOUR AD IZ 6	S	63g	3.2	0.335	MR△	+2" / -2"	\$250.00
TOUR AD IZ 6	X	65g	3.2	0.335	MR△	+2" / -2"	\$250.00



MODEL	FLEX	WEIGHT	TORQUE	TIP SIZE	DR ROTATION	MAX/MIN CUSTOM LENGTH	UPCHARGE
TOUR AD DI 6	S	65g	3.3	0.335	LR△	+2" / -2"	\$250.00
TOUR AD DI 6	X	66.5g	3.3	0.335	HR△	+2" / -2"	\$250.00
TOUR AD DI 7	S	73.5g	3.2	0.335	MR△	+2" / -2"	\$250.00
TOUR AD DI 7	X	75g	3.1	0.335	MR△	+2" / -2"	\$250.00



MODEL	FLEX	WEIGHT	TORQUE	TIP SIZE	DR ROTATION	MAX/MIN CUSTOM LENGTH	UPCHARGE
Tour AD FI 6	S	66.5g	3.2	0.335	MR△	+2" / -2"	\$250.00
Tour AD FI 6	X	68g	3.2	0.335	MR△	+2" / -2"	\$250.00
Tour AD FI 7	S	75.5g	2.9	0.335	MR△	+2" / -2"	\$250.00
Tour AD FI 7	X	78g	2.9	0.335	MR△	+2" / -2"	\$250.00



MODEL	FLEX	WEIGHT	TORQUE	TIP SIZE	DR ROTATION	MAX/MIN CUSTOM LENGTH	UPCHARGE
TOUR AD CQ 5	S	56g	4.5	0.335	HR△	+2" / -2"	\$250.00
TOUR AD CQ 6	X	66g	3.4	0.335	HR△	+2" / -2"	\$250.00
TOUR AD CQ 6	S	64g	3.4	0.335	HR△	+2" / -2"	\$250.00
TOUR AD CQ 7	X	74g	3.2	0.335	HR△	+2" / -2"	\$250.00
TOUR AD CQ 7	S	73g	3.2	0.335	HR△	+2" / -2"	\$250.00



MODEL	FLEX	WEIGHT	TORQUE	TIP SIZE	DR ROTATION	MAX/MIN CUSTOM LENGTH	UPCHARGE
TOUR AD GC 5	S	53g	4.5	0.335	MR△	+2" / -2"	\$250.00
TOUR AD GC 6	S	62g	3.1	0.335	HR△	+2" / -2"	\$250.00
TOUR AD GC 6	X	65.5g	3.1	0.335	HR△	+2" / -2"	\$250.00

CUSTOM DRIVER / FWY SHAFT OPTIONS



GRAPHITE DESIGN



MODEL	FLEX	WEIGHT	TORQUE	TIP SIZE	DR ROTATION	MAX/MIN CUSTOM LENGTH	UPCHARGE
TOUR AD VF 5	S	56.5g	4.3	0.335	LR	+2"-2"	\$250.00
TOUR AD VF 5	X	59g	4.3	0.335	MR	+2"-2"	\$250.00
TOUR AD VF 6	S	66g	3.3	0.335	MR	+2"-2"	\$250.00
TOUR AD VF 6	X	67g	3.3	0.335	MR	+2"-2"	\$250.00
TOUR AD VF 7	S	74g	3.0	0.335	MR	+2"-2"	\$250.00
TOUR AD VF 7	X	75.5g	3.0	0.335	LR	+2"-2"	\$250.00
TOUR AD VF 8	X	85g	2.8	0.335	LR	+2"-2"	\$250.00

KBS



MODEL	FLEX	WEIGHT	TORQUE	TIP SIZE	DR ROTATION	MAX/MIN CUSTOM LENGTH	UPCHARGE
MAX HL 40	A	40g	5.7	0.335	HR	+2"-2"	\$50.00
MAX HL 42	R	42g	5.6	0.335	MR	+2"-2"	\$50.00
MAX HL 50	R	50g	5.4	0.335	MR	+2"-2"	\$50.00
MAX HL 52	S	52g	5.3	0.335	HR	+2"-2"	\$50.00

DRIVER/FWY SHAFTS

HYBRID SHAFTS

IRON SHAFTS

WEDGES

PUTTERS

SWING GRIPS

PUTTER GRIPS

BUILD

JUNIOR



CUSTOM DRIVER / FWY SHAFT OPTIONS



MCA

MODEL	FLEX	WEIGHT	TORQUE	TIP SIZE	DR ROTATION	MAX/MIN CUSTOM LENGTH	UPCHARGE
DIAMANA BB 43	A	44g	5.1	0.335	MR△	+2" / -2"	\$350.00
DIAMANA BB 53	R	50g	5.1	0.335	MR△	+2" / -2"	\$350.00
DIAMANA BB 53	S	54g	4.9	0.335	MR△	+2" / -2"	\$350.00
DIAMANA BB 63	S	61g	3.2	0.335	MR△	+2" / -2"	\$350.00
DIAMANA BB 63	X	62g	3.2	0.335	HR△	+2" / -2"	\$350.00
DIAMANA BB 73	S	70g	2.9	0.335	MR△	+2" / -2"	\$350.00
DIAMANA BB 73	X	71g	2.9	0.335	MR△	+2" / -2"	\$350.00

MODEL	FLEX	WEIGHT	TORQUE	TIP SIZE	DR ROTATION	MAX/MIN CUSTOM LENGTH	UPCHARGE
DIAMANA WB 53	S	54g	4.6	0.335	HR△	+2" / -2"	\$350.00
DIAMANA WB 63	S	62g	3.1	0.335	HR△	+2" / -2"	\$350.00
DIAMANA WB 63	X	63g	3.1	0.335	LR△	+2" / -2"	\$350.00
DIAMANA WB 73	S	70g	2.9	0.335	MR△	+2" / -2"	\$350.00
DIAMANA WB 73	X	72g	2.9	0.335	HR△	+2" / -2"	\$350.00
DIAMANA WB 83	X	83g	2.7	0.335	MR△	+2" / -2"	\$350.00

MODEL	FLEX	WEIGHT	TORQUE	TIP SIZE	DR ROTATION	MAX/MIN CUSTOM LENGTH	UPCHARGE
DIAMANA RB 53	R	50g	4.9	0.335	MR△	+2" / -2"	\$350.00
DIAMANA RB 53	S	54g	4.9	0.335	MR△	+2" / -2"	\$350.00
DIAMANA RB 63	S	61g	3.2	0.335	HR△	+2" / -2"	\$350.00
DIAMANA RB 63	X	62g	3.2	0.335	HR△	+2" / -2"	\$350.00
DIAMANA RB 73	S	70g	2.6	0.335	MR△	+2" / -2"	\$350.00
DIAMANA RB 73	X	71g	2.9	0.335	HR△	+2" / -2"	\$350.00
DIAMANA RB 83	X	81g	2.8	0.335	MR△	+2" / -2"	\$350.00

DRIVER/FWY SHAFTS

HYBRID SHAFTS

IRON SHAFTS

WEDGES

PUTTERS

SWING GRIPS

PUTTER GRIPS

BUILD

JUNIOR



CUSTOM DRIVER / FWY SHAFT OPTIONS



MCA



MODEL	FLEX	WEIGHT	TORQUE	TIP SIZE	DR ROTATION	MAX/MIN CUSTOM LENGTH	UPCHARGE
TENSEI AV LIMITED BLUE 65	S	68g	3.9	0.335	MR△	+1.75" / -2"	\$-
TENSEI AV LIMITED BLUE 65	X	69g	3.4	0.335	MR△	+1.75" / -2"	\$-



MODEL	FLEX	WEIGHT	TORQUE	TIP SIZE	DR ROTATION	MAX/MIN CUSTOM LENGTH	UPCHARGE
TENSEI AV LIMITED BLACK 65	S	68g	3.5	0.335	LR△	+1.75" / -2"	\$-
TENSEI AV LIMITED BLACK 65	X	69g	3.4	0.335	LR△	+1.75" / -2"	\$-



MODEL	FLEX	WEIGHT	TORQUE	TIP SIZE	DR ROTATION	MAX/MIN CUSTOM LENGTH	UPCHARGE
TENSEI 1K BLACK 65	S	67g	3.6	0.335	MR△	+2" / -2"	\$-
TENSEI 1K BLACK 65	X	68g	3.5	0.335	LR△	+2" / -2"	\$-
TENSEI 1K BLACK 75	S	78g	3.6	0.335	LR△	+2" / -2"	\$-
TENSEI 1K BLACK 75	X	79g	3.5	0.335	LR△	+2" / -2"	\$-
TENSEI 1K BLACK 85	S	89g	3.2	0.335	MR△	+2" / -2"	\$-
TENSEI 1K BLACK 85	X	90g	3.2	0.335	LR△	+2" / -2"	\$-

DRIVER/FWY SHAFTS

HYBRID SHAFTS

IRON SHAFTS

WEDGES

PUTTERS

SWING GRIPS

PUTTER GRIPS

BUILD

JUNIOR



CUSTOM DRIVER / FWY SHAFT OPTIONS



MCA



MODEL	FLEX	WEIGHT	TORQUE	TIP SIZE	DR ROTATION	MAX/MIN CUSTOM LENGTH	UPCHARGE
KAI'LI BLUE CB 60 DW	X	63.5g	4.1	0.335	HR△	+2" / -2"	\$-
KAI'LI BLUE CB 60 DW	S	61.5g	4.1	0.335	MR△	+2" / -2"	\$-
KAI'LI BLUE CB 60 DW	R	59.5g	4.2	0.335	LR△	+2" / -2"	\$-



MODEL	FLEX	WEIGHT	TORQUE	TIP SIZE	DR ROTATION	MAX/MIN CUSTOM LENGTH	UPCHARGE
KAI'LI WHITE DW 60	X	69g	4.1	0.335	MR△	+2" / -2"	\$-
KAI'LI WHITE DW 60	S	68g	4.1	0.335	LR△	+2" / -2"	\$-
KAI'LI WHITE DW 70	S	75g	3.8	0.335	HR△	+2" / -2"	\$-
KAI'LI WHITE DW 70	X	77g	3.7	0.335	HR△	+2" / -2"	\$-



MODEL	FLEX	WEIGHT	TORQUE	TIP SIZE	DR ROTATION	MAX/MIN CUSTOM LENGTH	UPCHARGE
VANQUISH 40	R2-A	47g	5.4	0.335	HR△	+2" / -2"	\$-
VANQUISH 40	R	48g	5.4	0.335	MR△	+2" / -2"	\$-
VANQUISH 50	R	55g	4.2	0.335	HR△	+2" / -2"	\$-
VANQUISH 50	S	57g	4.2	0.335	HR△	+2" / -2"	\$-

DRIVER/FWY SHAFTS

HYBRID SHAFTS

IRON SHAFTS

WEDGES

PUTTERS

SWING GRIPS

PUTTER GRIPS

BUILD

JUNIOR



CUSTOM DRIVER / FWY SHAFT OPTIONS



PROJECT X



MODEL	FLEX	WEIGHT	TORQUE	TIP SIZE	DR ROTATION	MAX/MIN CUSTOM LENGTH	UPCHARGE
CYPHER 40	4.0 (L)	47g	6.0	0.335	HR△	+2" / -2"	\$50.00
CYPHER 40	5.0 (A)	47g	5.5	0.335	LR△	+2" / -2"	\$50.00
CYPHER 50	5.5 (R)	55g	4.3	0.335	MR△	+2" / -2"	\$50.00
CYPHER 50	6.0 (S)	56g	4.2	0.335	MR△	+2" / -2"	\$50.00



MODEL	FLEX	WEIGHT	TORQUE	TIP SIZE	DR ROTATION	MAX/MIN CUSTOM LENGTH	UPCHARGE
HZRDUS BLACK Gen 5 60	5.5 (R)	65g	3.5	0.335	MR△	+2" / -2"	\$-
HZRDUS BLACK Gen 5 60	6.0 (S)	65g	3.2	0.335	MR△	+2" / -2"	\$-
HZRDUS BLACK Gen 5 60	6.5 (X)	66g	3.0	0.335	HR△	+2" / -2"	\$-
HZRDUS BLACK Gen 5 70	6.0 (S)	72g	3.1	0.335	MR△	+2" / -2"	\$-
HZRDUS BLACK Gen 5 70	6.5 (X)	74g	2.9	0.335	HR△	+2" / -2"	\$-
HZRDUS BLACK Gen 5 80	6.0 (S)	80g	3.0	0.335	LR△	+2" / -2"	\$-
HZRDUS BLACK Gen 5 80	6.5 (X)	81g	2.8	0.335	MR△	+2" / -2"	\$-



MODEL	FLEX	WEIGHT	TORQUE	TIP SIZE	DR ROTATION	MAX/MIN CUSTOM LENGTH	UPCHARGE
DENALI FROST RED 40	4.0 (L)	48g	5.4	0.335	HR△	+2" / -2"	\$-
DENALI FROST RED 50	5.0 (A)	53g	5.1	0.335	HR△	+2" / -2"	\$-
DENALI FROST RED 50	5.5 (R)	55g	5.0	0.335	HR△	+2" / -2"	\$-
DENALI FROST RED 60	6.0 (S)	65g	3.8	0.335	HR△	+2" / -2"	\$-



MODEL	FLEX	WEIGHT	TORQUE	TIP SIZE	DR ROTATION	MAX/MIN CUSTOM LENGTH	UPCHARGE
DENALI FROST BLUE 60	6.0 (S)	64g	3.9	0.335	MR△	+2" / -2"	\$-
DENALI FROST BLUE 60	6.5 (X)	64g	3.8	0.335	MR△	+2" / -2"	\$-
DENALI FROST BLUE 70	6.0 (S)	74g	3.8	0.335	MR△	+2" / -2"	\$-
DENALI FROST BLUE 70	6.5 (X)	74g	3.8	0.335	MR△	+2" / -2"	\$-



MODEL	FLEX	WEIGHT	TORQUE	TIP SIZE	DR ROTATION	MAX/MIN CUSTOM LENGTH	UPCHARGE
DENALI FROST BLACK 60	6.0 (S)	66g	3.5	0.335	LR△	+2" / -2"	\$-
DENALI FROST BLACK 60	6.5 (X)	67g	3.5	0.335	LR△	+2" / -2"	\$-
DENALI FROST BLACK 70	6.0 (S)	73g	3.2	0.335	LR△	+2" / -2"	\$-
DENALI FROST BLACK 70	6.5 (X)	74g	3.2	0.335	LR△	+2" / -2"	\$-

CUSTOM DRIVER / FWY SHAFT OPTIONS



PROJECT X



MODEL	FLEX	WEIGHT	TORQUE	TIP SIZE	DR ROTATION	MAX/MIN CUSTOM LENGTH	UPCHARGE
DENALI BLUE 60	6.0 (S)	65g	3.7	0.335	MR△	+2" / -2"	\$-
DENALI BLUE 60	6.5 (X)	65g	3.5	0.335	LR△	+2" / -2"	\$-
DENALI BLUE 70	6.0 (S)	73g	3.1	0.335	LR△	+2" / -2"	\$-
DENALI BLUE 70	6.5 (X)	73g	3.0	0.335	LR△	+2" / -2"	\$-



MODEL	FLEX	WEIGHT	TORQUE	TIP SIZE	DR ROTATION	MAX/MIN CUSTOM LENGTH	UPCHARGE
DENALI BLACK 60	6.0 (S)	65g	3.9	0.335	MR△	+2" / -2"	\$-
DENALI BLACK 60	6.5 (X)	69g	3.7	0.335	LR△	+2" / -2"	\$-
DENALI BLACK 70	6.0 (S)	75g	3.6	0.335	LR△	+2" / -2"	\$-
DENALI BLACK 70	6.5 (X)	76g	3.2	0.335	LR△	+2" / -2"	\$-



MODEL	FLEX	WEIGHT	TORQUE	TIP SIZE	DR ROTATION	MAX/MIN CUSTOM LENGTH	UPCHARGE
DENALI RED 40	4.0 (L)	48g	6.2	0.335	MR△	+2" / -2"	\$-
DENALI RED 50	5.0 (A)	52g	5.9	0.335	MR△	+2" / -2"	\$-
DENALI RED 50	5.5 (R)	53g	5.4	0.335	HR△	+2" / -2"	\$-
DENALI RED 60	6.0 (S)	60g	4.0	0.335	HR△	+2" / -2"	\$-
DENALI RED 60	6.5 (X)	62g	3.8	0.335	HR△	+2" / -2"	\$-

UST



MODEL	FLEX	WEIGHT	TORQUE	TIP SIZE	DR ROTATION	MAX/MIN CUSTOM LENGTH	UPCHARGE
LIN-Q POWERCORE BLUE 6	S	68g	3.5	0.335	MR△	+2" / -2"	\$150.00
LIN-Q POWERCORE BLUE 6	X	72g	3.5	0.335	HR△	+2" / -2"	\$150.00



MODEL	FLEX	WEIGHT	TORQUE	TIP SIZE	DR ROTATION	MAX/MIN CUSTOM LENGTH	UPCHARGE
LIN-Q POWERCORE RED 6	S	69g	3.3	0.335	MR△	+2" / -2"	\$150.00
LIN-Q POWERCORE RED 6	X	67g	3.4	0.335	HR△	+2" / -2"	\$150.00



MODEL	FLEX	WEIGHT	TORQUE	TIP SIZE	DR ROTATION	MAX/MIN CUSTOM LENGTH	UPCHARGE
LIN-Q POWERCORE WHITE 6	S	70g	3.3	0.335	LR△	+2" / -2"	\$150.00
LIN-Q POWERCORE WHITE 6	X	66g	3.5	0.335	MR△	+2" / -2"	\$150.00

CUSTOM DRIVER / FWY SHAFT OPTIONS



UST



MODEL	FLEX	WEIGHT	TORQUE	TIP SIZE	DR ROTATION	MAX/MIN CUSTOM LENGTH	UPCHARGE
25 PROFORCE V2 60	F3 (R)	65g	3.0	0.335	HR△	+2" / -2"	\$50.00
25 PROFORCE V2 60	F4 (S)	66g	3.0	0.335	MR△	+2" / -2"	\$50.00
25 PROFORCE V2 70	F4 (S)	76g	2.2	0.335	MR△	+2" / -2"	\$50.00
25 PROFORCE V2 70	F5 (X)	76g	2.2	0.335	HR△	+2" / -2"	\$50.00



MODEL	FLEX	WEIGHT	TORQUE	TIP SIZE	DR ROTATION	MAX/MIN CUSTOM LENGTH	UPCHARGE
HELIUM NCT 4	L	44g	6.2	0.335	HR△	+2" / -2"	\$50.00
HELIUM NCT 5	A	52g	6.0	0.335	HR△	+2" / -2"	\$50.00
HELIUM NCT 5	R	54g	6.0	0.335	MR△	+2" / -2"	\$50.00
HELIUM NCT 5	S	56g	6.0	0.335	HR△	+2" / -2"	\$50.00

DRIVER/FWY SHAFTS

HYBRID SHAFTS

IRON SHAFTS

WEDGES

PUTTERS

SWING GRIPS

PUTTER GRIPS

BUILD

JUNIOR



CUSTOM HYBRID SHAFT OPTIONS



AEROTECH



MODEL	FLEX	WEIGHT	TORQUE	TIP SIZE	MAX/MIN CUSTOM LENGTH	UPCHARGE
STEELFIBER i95	R	95g	2.5	0.370	+1" / -2"	\$50.00
STEELFIBER i95	S	95g	2.4	0.370	+1" / -2"	\$50.00
STEELFIBER i80	S	85g	2.9	0.370	+1" / -2"	\$50.00
STEELFIBER i80	R	85g	2.9	0.370	+1" / -2"	\$50.00
STEELFIBER i70	S	74g	3.0	0.370	+1" / -2"	\$50.00
STEELFIBER i70	R	74g	3.3	0.370	+1" / -2"	\$50.00

FUJIKURA



MODEL	FLEX	WEIGHT	TORQUE	TIP SIZE	MAX/MIN CUSTOM LENGTH	UPCHARGE
VENTUS RED W/VELOCORE+ 7	R	74g	3	0.370	+2"/-2"	\$190.00
VENTUS RED W/VELOCORE+ 7	S	75g	2.8	0.370	+2"/-2"	\$190.00
VENTUS RED W/VELOCORE+ 8	S	85.5g	2.6	0.370	+2"/-2"	\$190.00
VENTUS RED W/VELOCORE+ 9	X	94.5g	2.2	0.370	+2"/-2"	\$190.00



MODEL	FLEX	WEIGHT	TORQUE	TIP SIZE	MAX/MIN CUSTOM LENGTH	UPCHARGE
VENTUS BLUE W/VELOCORE+ 7	R	73.5g	3	0.370	+2"/-2"	\$190.00
VENTUS BLUE W/VELOCORE+ 7	S	74.5g	2.8	0.370	+2"/-2"	\$190.00
VENTUS BLUE W/VELOCORE+ 8	S	85.5g	2.6	0.370	+2"/-2"	\$190.00
VENTUS BLUE W/VELOCORE+ 8	X	85.5g	2.4	0.370	+2"/-2"	\$190.00
VENTUS BLUE W/VELOCORE+ 9	S	94g	2.4	0.370	+2"/-2"	\$190.00



MODEL	FLEX	WEIGHT	TORQUE	TIP SIZE	MAX/MIN CUSTOM LENGTH	UPCHARGE
VENTUS BLACK W/VELOCORE+ 9	X	95g	2.2	0.370	+2"/-2"	\$190.00

DRIVER/WY SHAFTS

HYBRID SHAFTS

IRON SHAFTS

WEDGES

PUTTERS

SWING GRIPS

PUTTER GRIPS

BUILD

JUNIOR



CUSTOM HYBRID SHAFT OPTIONS



GRAPHITE DESIGN



MODEL	FLEX	WEIGHT	TORQUE	TIP SIZE	MAX/MIN CUSTOM LENGTH	UPCHARGE
TOUR AD DI 85 HYBRID	S	88g	2.4	0.370	+2" / -2"	\$150.00
TOUR AD DI 85 HYBRID	X	88g	2.4	0.370	+2" / -2"	\$150.00



MODEL	FLEX	WEIGHT	TORQUE	TIP SIZE	MAX/MIN CUSTOM LENGTH	UPCHARGE
TOUR AD IZ 85 HYBRID	S	86g	2.4	0.370	+2" / -2"	\$150.00
TOUR AD IZ 85 HYBRID	X	88g	2.4	0.370	+2" / -2"	\$150.00
TOUR AD IZ 75 HYBRID	R	76g	3.1	0.370	+2" / -2"	\$150.00



MODEL	FLEX	WEIGHT	TORQUE	TIP SIZE	TMAX/MIN CUSTOM LENGTH	UPCHARGE
TOUR AD VF HY 75	R	76g	3.0	0.370	+2"/-2"	\$150.00
TOUR AD VF HY 75	S	76.5g	3.0	0.370	+2"/-2"	\$150.00
TOUR AD VF HY 85	S	86.5g	2.5	0.370	+2"/-2"	\$150.00
TOUR AD VF HY 95	S	95g	2.5	0.370	+2"/-2"	\$150.00
TOUR AD VF HY 95	X	97g	2.5	0.370	+2"/-2"	\$150.00

KBS



MODEL	FLEX	WEIGHT	TORQUE	TIP SIZE	MAX/MIN CUSTOM LENGTH	UPCHARGE
TOUR	S	120g	1.3	0.370	+2" / -2"	\$-
TOUR	X	130g	1.2	0.355	+0.5" / -2"	\$-



MODEL	FLEX	WEIGHT	TORQUE	TIP SIZE	MAX/MIN CUSTOM LENGTH	UPCHARGE
MAX GRAPHITE 45	L	45g	6.5	0.370	+1" / -2"	\$15.00
MAX GRAPHITE 55	A	55g	4.8	0.370	+1" / -2"	\$15.00
MAX GRAPHITE 65	R	65g	3.8	0.370	+1" / -2"	\$15.00
MAX GRAPHITE 75	S	75g	3.0	0.370	+1" / -2"	\$15.00

CUSTOM HYBRID SHAFT OPTIONS



KBS



MODEL	FLEX	WEIGHT	TORQUE	TIP SIZE	MAX/MIN CUSTOM LENGTH	UPCHARGE
MAX HL 40 HYBRID	L	40g	5.0	0.370	+2" / -2"	\$15.00
MAX HL 50 HYBRID	A	50g	4.5	0.370	+2" / -2"	\$15.00
MAX HL 60 HYBRID	R	60g	4.0	0.370	+2" / -2"	\$15.00



MODEL	FLEX	WEIGHT	TORQUE	TIP SIZE	MAX/MIN CUSTOM LENGTH	UPCHARGE
MAX 85 MT	R	93.3g	2.1	0.370	+2" / -2"	\$-
MAX 85 MT	S	93.3g	2.1	0.370	+2" / -2"	\$-



MODEL	FLEX	WEIGHT	TORQUE	TIP SIZE	MAX/MIN CUSTOM LENGTH	UPCHARGE
C TAPER	S	120g	1.9	0.370	+2" / -2"	\$15.00
C TAPER	X	130g	1.8	0.370	+2" / -2"	\$15.00



MODEL	FLEX	WEIGHT	TORQUE	TIP SIZE	MAX/MIN CUSTOM LENGTH	UPCHARGE
C-TAPER LITE	R	105g	2.2	0.355	+0.5" / -2"	\$15.00
C-TAPER LITE	S	110g	2.1	0.355	+0.5" / -2"	\$15.00
C-TAPER LITE	X	115g	2.0	0.355	+0.5" / -2"	\$15.00



MODEL	FLEX	WEIGHT	TORQUE	TIP SIZE	MAX/MIN CUSTOM LENGTH	UPCHARGE
\$ TAPER CHROME	S	120g	1.3	0.355	+0.5" / -2"	\$15.00
\$ TAPER CHROME	X	130g	1.2	0.355	+0.5" / -2"	\$15.00



MODEL	FLEX	WEIGHT	TORQUE	TIP SIZE	MAX/MIN CUSTOM LENGTH	UPCHARGE
REAX 50 HY	S	59	2.8	0.370	+1.75" / -2"	\$-
REAX 50 HY	R	58	2.9	0.370	+1.75" / -2"	\$-
REAX 50 HY	A	58	3.1	0.370	+1.75" / -2"	\$-

DRIVER/WY SHAFTS

HYBRID SHAFTS

IRON SHAFTS

WEDGES

PUTTERS

SWING GRIPS

PUTTER GRIPS

BUILD

JUNIOR



CUSTOM HYBRID SHAFT OPTIONS



TM / KBS

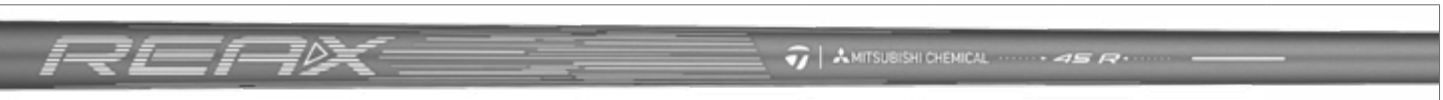

MODEL	FLEX	WEIGHT	TORQUE	TIP SIZE	LAUNCH	SPIN	MAX/MIN CUSTOM LENGTH	UPCHARGE
REAX 45 HY	R	49	3.8	0.370	+1.75" / -2"	Mid-Low	+1.75" / -2"	\$-
REAX 45 HY	A	49	3.8	0.370	+1.75" / -2"	Mid-Low	+1.75" / -2"	\$-
REAX 40 HY	L	43	3.8	0.370	+1.75" / -2"	Mid-Low	+1.75" / -2"	\$-



MODEL	FLEX	WEIGHT	TORQUE	TIP SIZE	MAX/MIN CUSTOM LENGTH	UPCHARGE
REAX 85 HY (MCA)	X	81	3.4	0.370	+2" / -2"	\$-
REAX 75	S	76	2.8	0.370	+1.75" / -2"	\$-
REAX 65	R	67	3.2	0.370	+1.75" / -2"	\$-
REAX 55	A	57	3.4	0.370	+1.75" / -2"	\$-

MCA



MODEL	FLEX	WEIGHT	TORQUE	TIP SIZE	MAX/MIN CUSTOM LENGTH	UPCHARGE
KAILI BLUE HB 95	X	96g	3.0	0.370	+1.75" / -2"	\$-
KAILI BLUE HB 85	S	79.5g	3.4	0.370	+1.75" / -2"	\$-



MODEL	FLEX	WEIGHT	TORQUE	TIP SIZE	MAX/MIN CUSTOM LENGTH	UPCHARGE
TENSEI AV LIMITED BLUE 65 HY	R	68g	4.0	0.370	+1.75" / -2"	\$-
TENSEI AV LIMITED BLUE 75 HY	S	79g	3.4	0.370	+1.75" / -2"	\$-
TENSEI AV LIMITED BLUE 85 HY	X	95g	3.0	0.370	+1.75" / -2"	\$-



MODEL	FLEX	WEIGHT	TORQUE	TIP SIZE	MAX/MIN CUSTOM LENGTH	UPCHARGE
TENSEI 1K BLACK HY 85	S	87g	2.5	0.370	+2"/-2"	\$-
TENSEI 1K BLACK HY 85	X	91g	2.4	0.370	+2"/-2"	\$-
TENSEI 1K BLACK HY 95	X	102g	2.3	0.370	+2"/-2"	\$-



MODEL	FLEX	WEIGHT	TORQUE	TIP SIZE	LAUNCH	SPIN	MAX/MIN CUSTOM LENGTH	UPCHARGE
VANQUISH 5	R2-A	62g	5.8	0.370	High	Mid-High	+1.75" / -2"	\$-
VANQUISH 5	R	62g	5.7	0.370	High	Mid-High	+1.75" / -2"	\$-

CUSTOM HYBRID SHAFT OPTIONS



PROJECT X



MODEL	FLEX	WEIGHT	TORQUE	TIP SIZE	MAX/MIN CUSTOM LENGTH	UPCHARGE
HZRDU5 BLACK HY 80 G5	6.0 (S)	82g	2.2	0.370	+2" / -2"	\$-
HZRDU5 BLACK HY 80 G5	6.5 (X)	83g	2.1	0.370	+2" / -2"	\$-
HZRDU5 BLACK HY 90 G5	6.0 (S)	90g	2.2	0.370	+2" / -2"	\$-
HZRDU5 BLACK HY 90 G5	6.5 (X)	91g	2.1	0.370	+2" / -2"	\$-



MODEL	FLEX	WEIGHT	TORQUE	TIP SIZE	MAX/MIN CUSTOM LENGTH	UPCHARGE
EVENFLOW RIPTIDE 80 HY	6.0 (S)	88g	3.2	0.370	+2" / -2"	\$-
EVENFLOW RIPTIDE 80 HY	6.5 (X)	88g	3.2	0.370	+2" / -2"	\$-



MODEL	FLEX	WEIGHT	TORQUE	TIP SIZE	MAX/MIN CUSTOM LENGTH	UPCHARGE
PROJECT X	6.0 (S)	120g	1.4	0.370	+1" / -2"	\$-
PROJECT X	6.5 (X)	125g	1.2	0.370	+1" / -2"	\$-

DRIVER/WY SHAFTS

HYBRID SHAFTS

IRON SHAFTS

WEDGES

PUTTERS

SWING GRIPS

PUTTER GRIPS

BUILD

JUNIOR



CUSTOM HYBRID SHAFT OPTIONS



TRUE TEMPER



MODEL	FLEX	WEIGHT	TORQUE	TIP SIZE	MAX/MIN CUSTOM LENGTH	UPCHARGE
DYNAMIC GOLD	S300	130g	1.8	0.370	+1.25" / -2"	\$-
DYNAMIC GOLD	X100	130g	1.5	0.370	+1.25" / -2"	\$-

UST



MODEL	FLEX	WEIGHT	TORQUE	TIP SIZE	MAX/MIN CUSTOM LENGTH	UPCHARGE
PROFORCE V2 8 HY	F3 (R)	84g	3.2	0.370	+1" / -2"	\$-
PROFORCE V2 8 HY	F4 (S)	86g	3.2	0.370	+1" / -2"	\$-
PROFORCE V2 8 HY	F5 (X)	90g	3.2	0.370	+1" / -2"	\$-



MODEL	FLEX	WEIGHT	TORQUE	TIP SIZE	MAX/MIN CUSTOM LENGTH	UPCHARGE
RECOIL DART 65	F2 (A)	61g	5.2	0.370	+1" / -2"	\$15.00
RECOIL DART 65	F3 (R)	64g	5.2	0.370	+1" / -2"	\$15.00
RECOIL DART 75	F4 (S)	78g	3.9	0.370	+1" / -2"	\$15.00
RECOIL DART 90	F4 (S)	90g	2.5	0.370	+0.5" / -2"	\$15.00
RECOIL DART 90	F3 (R)	90g	2.6	0.370	+0.5" / -2"	\$15.00
RECOIL DART 105 (P-UDI & P-DHY ONLY)	F4 (S)	106g	2.0	0.355	+0.5" / -2"	\$-
RECOIL DART 105 (P-UDI & P-DHY ONLY)	F4 (X)	106g	2.0	0.355	+0.5" / -2"	\$-

DRIVER/WY SHAFTS

HYBRID SHAFTS

IRON SHAFTS

WEDGES

PUTTERS

SWING GRIPS

PUTTER GRIPS

BUILD

JUNIOR



CUSTOM IRON SHAFT OPTIONS



AEROTECH



MODEL	FLEX	WEIGHT	TORQUE	MAX/MIN P-SERIES/WEDGE	MAX/MIN Qi	UPCHARGE
STEELFIBER i95	R	95g	2.5	+2" / -2"	+2" / -2"	\$50.00
STEELFIBER i95	S	95g	2.4	+2" / -2"	+2" / -2"	\$50.00
STEELFIBER i80	S	85g	2.9	+2" / -2"	+2" / -2"	\$50.00
STEELFIBER i80	R	85g	2.9	+2" / -2"	+2" / -2"	\$50.00
STEELFIBER i70	R	74g	3.0	+2" / -2"	+2" / -2"	\$50.00
STEELFIBER i70	A	74g	3.3	+2" / -2"	+2" / -2"	\$50.00

FUJIKURA



MODEL	FLEX	WEIGHT	TORQUE	MAX/MIN P-SERIES/WEDGE	MAX/MIN Qi	UPCHARGE
AXIOM 105	X	104.5-102.5	1.7-1.3	+2" / -2"	+2" / -2"	\$100.00
AXIOM 105	S	104.5-102.5	1.8-1.4	+2" / -2"	+2" / -2"	\$100.00

DRIVER/WY SHAFTS

HYBRID SHAFTS

IRON SHAFTS

WEDGES

PUTTERS

SWING GRIPS

PUTTER GRIPS

BUILD

JUNIOR



CUSTOM IRON SHAFT OPTIONS



KBS

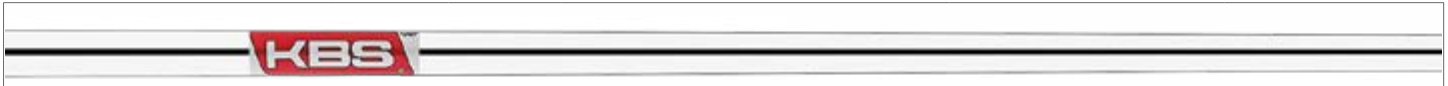

MODEL	FLEX	WEIGHT	TORQUE	MAX/MIN CUSTOM LENGTH P-SERIES / WEDGE	MAX/MIN CUSTOM LENGTH Qi	UPCHARGE
MAX LITE	S	83 g	2.3	+2" / -2"	+2" / -2"	\$-
MAX LITE	R	83 g	2.4	+2" / -2"	+2" / -2"	\$-



MODEL	FLEX	WEIGHT	TORQUE	MAX/MIN CUSTOM LENGTH P-SERIES / WEDGE	MAX/MIN CUSTOM LENGTH Qi	UPCHARGE
TOUR LITE	R	95g	2.5	+2" / -2"	+2" / -2"	\$-
TOUR LITE	S	100g	2.3	+2" / -2"	+2" / -2"	\$-
TOUR LITE	X	105	2.1	+2" / -2"	+2" / -2"	\$-



MODEL	FLEX	WEIGHT	TORQUE	MAX/MIN CUSTOM LENGTH P-SERIES / WEDGE	MAX/MIN CUSTOM LENGTH Qi	UPCHARGE
TOUR BLACK	S	120	1.3	+2" / -2"	+2" / -2"	\$15.00
TOUR BLACK	X	130	1.2	+2" / -2"	+2" / -2"	\$15.00



MODEL	FLEX	WEIGHT	TORQUE	MAX/MIN CUSTOM LENGTH P-SERIES / WEDGE	MAX/MIN CUSTOM LENGTH Qi	UPCHARGE
TOUR	S	120g	1.3	+2" / -2"	+2" / -2"	\$-
TOUR	X	130g	1.2	+2" / -2"	+2" / -2"	\$-



MODEL	FLEX	WEIGHT	TORQUE	MAX/MIN CUSTOM LENGTH P-SERIES / WEDGE	MAX/MIN CUSTOM LENGTH Qi	UPCHARGE
\$ TAPER CHROME	S	120g	1.3	+2" / -2"	+2" / -2"	\$15.00
\$ TAPER CHROME	X	130g	1.2	+2" / -2"	+2" / -2"	\$15.00



MODEL	FLEX	WEIGHT	TORQUE	MAX/MIN CUSTOM LENGTH P-SERIES / WEDGE	MAX/MIN CUSTOM LENGTH Qi	UPCHARGE
C-TAPER	S	120g	1.9	+2" / -2"	+2" / -2"	\$15.00
C-TAPER	X	130g	1.8	+2" / -2"	+2" / -2"	\$15.00

DRIVER/WY SHAFTS

HYBRID SHAFTS

IRON SHAFTS

WEDGES

PUTTERS

SWING GRIPS

PUTTER GRIPS

BUILD

JUNIOR



CUSTOM IRON SHAFT OPTIONS



KBS



MODEL	FLEX	WEIGHT	TORQUE	MAX/MIN CUSTOM LENGTH P-SERIES / WEDGE	MAX/MIN CUSTOM LENGTH Qi	UPCHARGE
C-TAPER LITE	R	105g	2.2	+2" / -2"	+2" / -2"	\$15.00
C-TAPER LITE	S	110g	2.1	+2" / -2"	+2" / -2"	\$15.00
C-TAPER LITE	X	115g	2	+2" / -2"	+2" / -2"	\$15.00



MODEL	FLEX	WEIGHT	TORQUE	MAX/MIN CUSTOM LENGTH P-SERIES	MAX/MIN CUSTOM LENGTH Qi	UPCHARGE
MAX 85 MT	R	93.3g	2.1	+2" / -2"	+2" / -2"	\$-
MAX 85 MT	S	93.3g	2.1	+2" / -2"	+2" / -2"	\$-



MODEL	FLEX	WEIGHT	TORQUE	MAX/MIN CUSTOM LENGTH P-SERIES	MAX/MIN CUSTOM LENGTH Qi	UPCHARGE
MAX GRAPHITE 45	L	45g	6.5	+2" / -2"	+2" / -2"	\$15.00
MAX GRAPHITE 55	A	55g	4.8	+2" / -2"	+2" / -2"	\$15.00
MAX GRAPHITE 65	R	65g	3.8	+2" / -2"	+2" / -2"	\$15.00
MAX GRAPHITE 75	S	75g	3	+2" / -2"	+2" / -2"	\$15.00



MODEL	FLEX	WEIGHT	TORQUE	MAX/MIN CUSTOM LENGTH WEDGE	MAX/MIN CUSTOM LENGTH Qi	UPCHARGE
HI-REV-2.0 115 WEDGE	WEDGE R	115g	1.3	+2" / -2"	NA	\$-

KBS



MODEL	FLEX	WEIGHT	TORQUE	MAX/MIN CUSTOM LENGTH WEDGE	MAX/MIN CUSTOM LENGTH Qi	UPCHARGE
REAX 75	S	76g	2.8	+2" / -2"	+2" / -2"	\$-
REAX 65	R	67g	3.2	+2" / -2"	+2" / -2"	\$-
REAX 55	A	57g	3.4	+2" / -2"	+2" / -2"	\$-

DRVR/FW SHAFTS

HYBRID SHAFTS

IRON SHAFTS

WEDGES

PUTTERS

SWING GRIPS

PUTTER GRIPS

BUILD

JUNIOR



CUSTOM IRON SHAFT OPTIONS



KBS



MODEL	FLEX	WEIGHT	TORQUE	MAX/MIN CUSTOM LENGTH P-SERIES / WEDGE	MAX/MIN CUSTOM LENGTH Qi	UPCHARGE
REAX 50 HL	S	51g	6.3	+2" / -2"	+2" / -2"	\$-
REAX 50 HL	R	50g	6.3	+2" / -2"	+2" / -2"	\$-
REAX 50 HL	A	48g	6.3	+2" / -2"	+2" / -2"	\$-



MODEL	FLEX	WEIGHT	TORQUE	MAX/MIN CUSTOM LENGTH P-SERIES / WEDGE	MAX/MIN CUSTOM LENGTH Qi	UPCHARGE
REAX 45 HL	L	46g	6.5	+2" / -2"	+2" / -2"	\$-



MODEL	FLEX	WEIGHT	TORQUE	MAX/MIN CUSTOM LENGTH P-SERIES / WEDGE	MAX/MIN CUSTOM LENGTH Qi	UPCHARGE
MMT 55	A	59g	3.5	+2" / -2"	+1.75" / -2"	\$15.00
MMT 65	R	63g	3.5	+2" / -2"	+1.75" / -2"	\$15.00
MMT 75	S	74g	3.7	+2" / -2"	+1.75" / -2"	\$15.00
MMT 105	S	105g	2.8	+1.5" / -2"	+0.75" / -2"	\$15.00
MMT 105	TX	113g	2.8	+1.5" / -2"	+0.75" / -2"	\$15.00
MMT 125	S	124g	2.8	+1.5" / -2"	+0.75" / -2"	\$15.00
MMT 125	TX	125g	2.7	+1.5" / -2"	+0.75" / -2"	\$15.00

NIPPON

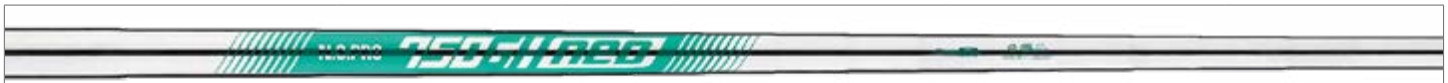

MODEL	FLEX	WEIGHT	TORQUE	MAX/MIN CUSTOM LENGTH P-SERIES / WEDGE	MAX/MIN CUSTOM LENGTH Qi	UPCHARGE
750GH NEO	R	74.5g	2.4	+0.75" / -2"	+0.25" / -2"	\$15.00
750GH NEO	S	78g	2.3	+0.75" / -2"	+0.25" / -2"	\$15.00



MODEL	FLEX	WEIGHT	TORQUE	MAX/MIN CUSTOM LENGTH P-SERIES / WEDGE	MAX/MIN CUSTOM LENGTH Qi	UPCHARGE
N.S. PRO MODUS 120	S	114g	1.7	+2" / -2"	+2" / -2"	\$15.00
N.S. PRO MODUS 120	X	120g	1.6	+2" / -2"	+2" / -2"	\$15.00

CUSTOM IRON SHAFT OPTIONS



NIPPON



MODEL	FLEX	WEIGHT	TORQUE	MAX/MIN CUSTOM LENGTH P-SERIES / WEDGE	MAX/MIN CUSTOM LENGTH Qi	UPCHARGE
N.S. PRO MODUS 105	S	106.5	1.7	+2" / -2"	+2" / -2"	\$-
N.S. PRO MODUS 105	R	103g	1.9	+2" / -2"	+2" / -2"	\$-
N.S. PRO MODUS 105	X	112g	1.6	+2" / -2"	+2" / -2"	\$-



MODEL	FLEX	WEIGHT	TORQUE	MAX/MIN CUSTOM LENGTH P-SERIES / WEDGE	MAX/MIN CUSTOM LENGTH Qi	UPCHARGE
N.S. PRO 950	S	98g	2	+0.75" / -2"	+0.25" / -2"	\$15.00
N.S. PRO 950	R	94.5g	2.3	+0.75" / -2"	+0.25" / -2"	\$15.00



MODEL	FLEX	WEIGHT	TORQUE	MAX/MIN CUSTOM LENGTH P-SERIES / WEDGE	MAX/MIN CUSTOM LENGTH Qi	UPCHARGE
MODUS 105 WEDGE	Wedge	111g	1.6	+2" / -2"	n/a	\$15.00

PROJECT X



MODEL	FLEX	WEIGHT	TORQUE	MAX/MIN CUSTOM LENGTH P-SERIES / WEDGE	MAX/MIN CUSTOM LENGTH Qi	UPCHARGE
PROJECT X	5.5 (R)	115g	2	+2" / -2"	+2" / -2"	\$-
PROJECT X	6.0 (S)	120g	1.4	+2" / -2"	+2" / -2"	\$-
PROJECT X	6.5 (X)	125g	1.2	+2" / -2"	+2" / -2"	\$-



MODEL	FLEX	WEIGHT	TORQUE	MAX/MIN CUSTOM LENGTH P-SERIES / WEDGE	MAX/MIN CUSTOM LENGTH Qi	UPCHARGE
PROJECT X RED	X (6.5)	120g	1.6	+2" / -2"	+2" / -2"	\$30.00
PROJECT X RED	S (6.0)	115g	1.8	+2" / -2"	+2" / -2"	\$30.00
PROJECT X RED	R (5.5)	110g	1.9	+2" / -2"	+2" / -2"	\$30.00



MODEL	FLEX	WEIGHT	TORQUE	MAX/MIN CUSTOM LENGTH WEDGE	MAX/MIN CUSTOM LENGTH Qi	UPCHARGE
PROJECT X WEDGE	6.0	120	1.5	+2" / -2"	n/a	\$15.00
PROJECT X WEDGE	6.5	125	1.3	+2" / -2"	n/a	\$15.00

CUSTOM IRON SHAFT OPTIONS



PROJECT X



MODEL	FLEX	WEIGHT	TORQUE	MAX/MIN CUSTOM LENGTH P-SERIES / WEDGE	MAX/MIN CUSTOM LENGTH Qi	UPCHARGE
PROJECT X LZ	5.5 (R)	115g	2.1	+2" / -2"	+1.75" / -2"	\$15.00
PROJECT X LZ	6.0 (S)	120g	1.7	+2" / -2"	+1.75" / -2"	\$15.00
PROJECT X LZ	6.5 (X)	125g	1.3	+2" / -2"	+1.75" / -2"	\$15.00

TRUE TEMPER

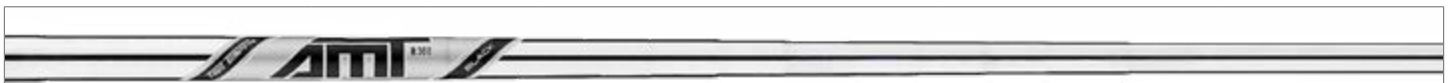

MODEL	FLEX	WEIGHT	TORQUE	MAX/MIN CUSTOM LENGTH P-SERIES / WEDGE	MAX/MIN CUSTOM LENGTH Qi	UPCHARGE
AMT BLACK	R300	94-112g	2.3-1.9	+2" / -2"	+2" / -2"	\$15.00
AMT BLACK	S300	95-113g	2.1-1.7	+2" / -2"	+2" / -2"	\$15.00



MODEL	FLEX	WEIGHT	TORQUE	MAX/MIN CUSTOM LENGTH P-SERIES / WEDGE	MAX/MIN CUSTOM LENGTH Qi	UPCHARGE
DYNAMIC GOLD	S300	130g	1.8	+2" / -2"	+1.75" / -2"	\$-
DYNAMIC GOLD	X100	130g	1.5	+2" / -2"	+1.75" / -2"	\$-



MODEL	FLEX	WEIGHT	TORQUE	MAX/MIN CUSTOM LENGTH P-SERIES / WEDGE	MAX/MIN CUSTOM LENGTH Qi	UPCHARGE
DYNAMIC GOLD MID 115	R300	114 g	1.8	+2" / -2"	+2" / -2"	\$-
DYNAMIC GOLD MID 115	S300	115 g	1.9	+2" / -2"	+2" / -2"	\$-
DYNAMIC GOLD MID 115	X100	116 g	2.0	+2" / -2"	+2" / -2"	\$-



MODEL	FLEX	WEIGHT	TORQUE	MAX/MIN CUSTOM LENGTH P-SERIES / WEDGE	MAX/MIN CUSTOM LENGTH Qi	UPCHARGE
DYNAMIC GOLD 120	S300	118g	1.7	+2 / -2"	+2 / -2"	\$15.00
DYNAMIC GOLD 120	X100	120g	1.7	+2 / -2"	+2 / -2"	\$15.00



MODEL	FLEX	WEIGHT	TORQUE	MAX/MIN CUSTOM LENGTH P-SERIES / WEDGE	MAX/MIN CUSTOM LENGTH Qi	UPCHARGE
DYNAMIC GOLD TOUR ISSUE	X100	130g	1.5	+2" / -2"	+2" / -2"	\$30.00
DYNAMIC GOLD TOUR ISSUE	S400	132g	1.6	+2" / -2"	+2" / -2"	\$30.00

CUSTOM IRON SHAFT OPTIONS



TRUE TEMPER



MODEL	FLEX	WEIGHT	TORQUE	MAX/MIN CUSTOM LENGTH WEDGE	MAX/MIN CUSTOM LENGTH Qi	UPCHARGE
DYNAMIC GOLD TOUR ISSUE BLACK - WEDGE ONLY	S400	132g	1.6	+2"/-2"	n/a	\$30.00



MODEL	FLEX	WEIGHT	TORQUE	MAX/MIN CUSTOM LENGTH P-SERIES / WEDGE	MAX/MIN CUSTOM LENGTH Qi	UPCHARGE
DYNAMIC GOLD 105	S300	104g	2	+2" / -2"	+1.75" / -2"	\$-
DYNAMIC GOLD 105	X100	106g	1.9	+2" / -2"	+1.75" / -2"	\$-



MODEL	FLEX	WEIGHT	TORQUE	MAX/MIN CUSTOM LENGTH WEDGE	MAX/MIN CUSTOM LENGTH Qi	UPCHARGE
DYNAMIC GOLD 95	R300	96g	2.1	+2" / -2"	+1.75" / -2"	\$15.00



MODEL	FLEX	WEIGHT	TORQUE	MAX/MIN CUSTOM LENGTH P-SERIES / WEDGE	MAX/MIN CUSTOM LENGTH Qi	UPCHARGE
ELEVATE 95 MPH	R	96g	2.1	+2" / -2"	+1.75" / -2"	\$-
ELEVATE 95 MPH	S	98g	2	+2" / -2"	+1.75" / -2"	\$-



MODEL	FLEX	WEIGHT	TORQUE	MAX/MIN CUSTOM LENGTH WEDGE	MAX/MIN CUSTOM LENGTH Qi	UPCHARGE
DYNAMIC GOLD WEDGE	WEDGE	130g	1.4	+2" / -2"	NA	\$15.00



MODEL	FLEX	WEIGHT	TORQUE	MAX/MIN CUSTOM LENGTH WEDGE	MAX/MIN CUSTOM LENGTH Qi	UPCHARGE
DYNAMIC GOLD TOUR ISSUE 115g	WEDGE	115g	2	+2" / -2"	N/A	\$-



MODEL	FLEX	WEIGHT	TORQUE	MAX/MIN CUSTOM LENGTH WEDGE	MAX/MIN CUSTOM LENGTH Qi	UPCHARGE
DYNAMIC GOLD TOUR ISSUE 115G (MG5)	Wedge	115g	2	+2"/-2"	n/a	\$-

DRIVER/WY SHAFTS

HYBRID SHAFTS

IRON SHAFTS

WEDGES

PUTTERS

SWING GRIPS

PUTTER GRIPS

BUILD

JUNIOR



CUSTOM IRON SHAFT OPTIONS



UST



MODEL	FLEX	WEIGHT	TORQUE	MAX/MIN CUSTOM LENGTH P-SERIES / WEDGE	MAX/MIN CUSTOM LENGTH Qi	UPCHARGE
RECOIL DART 65	A (F2)	61g	5.2	+2" / -2"	+2" / -2"	\$15.00
RECOIL DART 65	R (F3)	64g	5.2	+2" / -2"	+2" / -2"	\$15.00
RECOIL DART 75	S (F4)	78g	3.9	+2" / -2"	+2" / -2"	\$15.00
RECOIL DART 90	F4 (S)	90g	2.6	+2" / -2"	+2" / -2"	\$15.00
RECOIL DART 90	F3 (R)	90g	2.5	+2" / -2"	+2" / -2"	\$15.00



MODEL	FLEX	WEIGHT	TORQUE	MAX/MIN CUSTOM LENGTH P-SERIES / WEDGE	MAX/MIN CUSTOM LENGTH Qi	UPCHARGE
RECOIL ESX 450	L (F1)	52g	4.2	+2" / -2"	+2" / -2"	\$15.00
RECOIL ESX 460	A (F2)	59g	4.8	+2" / -2"	+2" / -2"	\$15.00
RECOIL ESX 460	R (F3)	64g	4.7	+2" / -2"	+2" / -2"	\$15.00
RECOIL ESX 460	S (F4)	67g	4.6	+2" / -2"	+2" / -2"	\$15.00



MODEL	FLEX	WEIGHT	TORQUE	MAX/MIN CUSTOM LENGTH P-SERIES / WEDGE	MAX/MIN CUSTOM LENGTH Qi	UPCHARGE
Recoil DART ESX - L	L	54g	4.2	+2" / -2"	+2" / -2"	\$15.00
Recoil DART ESX - A	A	60g	4.6	+2" / -2"	+2" / -2"	\$15.00
Recoil DART ESX - R	R	64g	4.5	+2" / -2"	+2" / -2"	\$15.00
Recoil DART ESX - S	S	67g	4.5	+2" / -2"	+2" / -2"	\$15.00



MODEL	FLEX	WEIGHT	TORQUE	MAX/MIN CUSTOM LENGTH P-SERIES / WEDGE	MAX/MIN CUSTOM LENGTH Qi	UPCHARGE
Recoil DART HDC - R	R	65g	5.0	+2" / -2"	+2" / -2"	\$15.00
Recoil DART HDC - S	S	79g	3.8	+2" / -2"	+2" / -2"	\$15.00



MODEL	FLEX	WEIGHT	TORQUE	MAX/MIN CUSTOM LENGTH P-SERIES / WEDGE	MAX/MIN CUSTOM LENGTH Qi	UPCHARGE
Recoil DART 80	Wedge	90g	2.6	+2" / -2"	n/a	\$-

DRIVER/WY SHAFTS

HYBRID SHAFTS

IRON SHAFTS

WEDGES

PUTTERS

SWING GRIPS

PUTTER GRIPS

BUILD

JUNIOR



CLUB GRIPS



GOLF PRIDE



MODEL	COLOR	SIZE	WEIGHT	BUTT SIZE	TYPE	UPCHARGE
CPX	GREY/BLUE	STANDARD	52g	0.600	ROUND	\$10.00
CPX MIDSIZE	GREY/BLUE	MID-SIZE	66g	0.600	ROUND	\$10.00



MODEL	COLOR	SIZE	WEIGHT	BUTT SIZE	TYPE	UPCHARGE
TOUR VELVET (TM Logo)	BLACK	STANDARD	51.5g	0.580	ROUND	\$0.00
TOUR VELVET	BLACK	STANDARD	51.5g	0.580	REMINDER	\$6.50
TOUR VELVET	BLACK	MID-SIZE	53.5g	0.600	ROUND	\$6.50
TOUR VELVET	BLACK	UNDERSIZE	45g	0.620	ROUND	\$6.50



MODEL	COLOR	SIZE	WEIGHT	BUTT SIZE	TYPE	UPCHARGE
TOUR VELVET CORD	BLACK	STANDARD	52.5g	0.580	ROUND	\$12.00



MODEL	COLOR	SIZE	WEIGHT	BUTT SIZE	TYPE	UPCHARGE
TOUR VELVET 360 Plus2 (W's Stock)	GRAY/WHITE	UNDERSIZE	44g	0.580	ROUND	\$0.00



MODEL	COLOR	SIZE	WEIGHT	BUTT SIZE	TYPE	UPCHARGE
TOUR WRAP 2G	BLACK	STANDARD	55g	0.600	ROUND	\$8.00
	BLACK	MID-SIZE	58g	0.600	ROUND	\$8.00
	WHITE	STANDARD	55g	0.600	ROUND	\$8.00

DRIVER/WY SHAFTS

HYBRID SHAFTS

IRON SHAFTS

WEDGES

PUTTERS

SWING GRIPS

PUTTER GRIPS

BUILD

JUNIOR



CLUB GRIPS



GOLF PRIDE



MODEL	COLOR	SIZE	WEIGHT	BUTT SIZE	TYPE	UPCHARGE
MCC	Lt BLUE / WHITE			0.600	ROUND	\$12.00
	RED / BLACK	STANDARD	46.5g	0.600	ROUND	\$12.00
	RED / BLACK	MID-SIZE	59g	0.600	ROUND	\$12.00
	WHITE / BLACK	STANDARD	46.5g	0.600	ROUND	\$12.00
	BLUE/WHITE	STANDARD	46.5g	0.600	ROUND	\$12.00
	RED/WHITE	STANDARD	46.5g	0.600	ROUND	\$12.00
	GREEN/GOLD	STANDARD	46.5g	0.600	ROUND	\$12.00
	BLACK/GOLD	STANDARD	46.5g	0.600	ROUND	\$12.00



MODEL	COLOR	SIZE	WEIGHT	BUTT SIZE	TYPE	UPCHARGE
CP2 PRO	BLACK / RED	STANDARD	50g	0.600	ROUND	\$10.00
	BLACK / RED	MID-SIZE	63.5g	0.600	ROUND	\$10.00



MODEL	COLOR	SIZE	WEIGHT	BUTT SIZE	TYPE	UPCHARGE
CP2 WRAP	BLACK / BLUE	STANDARD	50g	0.600	ROUND	\$10.00
	BLACK / BLUE	MID-SIZE	63.5g	0.600	ROUND	\$10.00
	BLACK / BLUE	JUMBO	80g	0.600	ROUND	\$10.00



MODEL	COLOR	SIZE	WEIGHT	BUTT SIZE	TYPE	UPCHARGE
MCC PLUS4	GRAY / BLACK	STANDARD	52g	0.600	ROUND	\$12.00
	GRAY / BLACK	MID-SIZE	66g	0.600	ROUND	\$12.00



MODEL	COLOR	SIZE	WEIGHT	BUTT SIZE	TYPE	UPCHARGE
MCC PLUS4 ALIGN	BLACK / GRAY	STANDARD	53g	0.600	REMINDER	\$12.00
MCC PLUS4 ALIGN	BLACK / GRAY	MID-SIZE	67g	0.600	REMINDER	\$12.00

CLUB GRIPS



GOLF PRIDE



MODEL	COLOR	SIZE	WEIGHT	BUTT SIZE	TYPE	UPCHARGE
MCC ALIGN MAX	BLACK/GREY	STANDARD	50g	0.600	REMINDER	\$12.00
MCC PLUS4 ALIGN MAX	BLACK/GREY	STANDARD	53g	0.600	REMINDER	\$12.00



MODEL	COLOR	SIZE	WEIGHT	BUTT SIZE	TYPE	UPCHARGE
Z GRIP PLUS2	BLACK / SILVER	STANDARD	52g	0.600	ROUND	\$0.00
Z GRIP PLUS2	BLACK / SILVER	STANDARD	58g	0.600	ROUND	\$0.00
Z GRIP PLUS2	GREY/BLACK	STANDARD	52g	0.580	ROUND	\$0.00
Z-GRIP PLUS2 (2024 P-SERIES)	BLACK/GREY	STANDARD	52g	0.580	ROUND	\$0.00



MODEL	COLOR	SIZE	WEIGHT	BUTT SIZE	TYPE	UPCHARGE
Z-GRIP LITE	BLACK/WHITE	STANDARD	43.5g	0.6	ROUND	\$0.00



MODEL	COLOR	SIZE	WEIGHT	BUTT SIZE	TYPE	UPCHARGE
Z GRIP (TM Logo)	RED	STANDARD	47g	0.600	ROUND	\$0.00
Z GRIP (TM Logo)	LIGHT BLUE	STANDARD	47g	0.600	ROUND	\$0.00
Z GRIP (TM Logo)	SILVER	STANDARD	47g	0.600	ROUND	\$0.00
Z GRIP (TM Logo)	BLACK	STANDARD	47g	0.600	ROUND	\$0.00

CLUB GRIPS



GOLF PRIDE



MODEL	COLOR	SIZE	WEIGHT	BUTT SIZE	TYPE	UPCHARGE
VICTORY COPPER	BLACK/COPPER	STANDARD	50g	0.600	ROUND	\$10.00



MODEL	COLOR	SIZE	WEIGHT	BUTT SIZE	TYPE	UPCHARGE
Z-CORD GRIP	BLACK/WHITE	STANDARD	50.5g	0.600	ROUND	\$12.00
Z-CORD GRIP	BLACK/WHITE	MIDSIZE	56g	0.600	ROUND	\$12.00

IONIC



MODEL	COLOR	SIZE	WEIGHT	BUTT SIZE	TYPE	UPCHARGE
STICKY 2.3	BLACK / BLACK	STANDARD	52g	0.600	TEXTURED	\$11.50
	BLUE / BLACK	STANDARD	52g	0.600	TEXTURED	\$11.50

LAMKIN



MODEL	COLOR	SIZE	WEIGHT	BUTT SIZE	TYPE	UPCHARGE
CROSSLINE	BLACK / WHITE	STANDARD	50g	0.580	ROUND	\$6.50
	BLACK / WHITE	MID-SIZE	62g	0.580	ROUND	\$6.50
	BLACK / WHITE	JUMBO	76g	0.580	ROUND	\$6.50



MODEL	COLOR	SIZE	WEIGHT	BUTT SIZE	TYPE	UPCHARGE
CROSSLINE 360 (HI-TOE 4)	BLACK/COPPER	STANDARD	52g	0.580	ROUND	\$0.00



MODEL	COLOR	SIZE	WEIGHT	BUTT SIZE	TYPE	UPCHARGE
CROSSLINE 360	GRAY/BLACK	MIDSIZE	61g	0.600	ROUND	\$-

LAMKIN



MODEL	COLOR	SIZE	WEIGHT	BUTT SIZE	TYPE	UPCHARGE
GENESIS CROSSLINE 360	BLACK/BLACK	STANDARD	50g	0.600	ROUND	\$0.00
	BLACK/BLACK	MIDSIZE	60g	0.600	ROUND	\$0.00



MODEL	COLOR	SIZE	WEIGHT	BUTT SIZE	TYPE	UPCHARGE
SONAR PLUS	BLACK / BLUE	STANDARD	53g	0.600	ROUND	\$10.00
	BLACK / BLUE	MID-SIZE	57g	0.600	ROUND	\$10.00
	BLACK / BLUE	JUMBO	77g	0.600	ROUND	\$10.00

SUPERSTROKE



MODEL	COLOR	SIZE	WEIGHT	BUTT SIZE	TYPE	UPCHARGE
CROSS COMFORT	BLACK / GRAY	STANDARD	48g	0.600	ROUND	\$10.00
	BLACK / GRAY	MIDSIZE	49g	0.600	ROUND	\$10.00



MODEL	COLOR	SIZE	WEIGHT	BUTT SIZE	TYPE	UPCHARGE
CROSSLINE 360 (HL Iron)	BLACK	STANDARD	43.5g	0.600	ROUND	\$ --
CROSSLINE 360 (Stock Iron)	BLACK	STANDARD	47g	0.600	ROUND	\$ --



MODEL	COLOR	SIZE	WEIGHT	BUTT SIZE	TYPE	UPCHARGE
REVL ELEMENT	BLACK / GRAY	STANDARD	46.5g	0.600	ROUND	\$10.00
	BLACK / GRAY	MIDSIZE	53g	0.600	ROUND	\$10.00



MODEL	COLOR	SIZE	WEIGHT	BUTT SIZE	TYPE	UPCHARGE
REVL PLAYER	BLACK / GRAY	STANDARD	49.5g	0.600	ROUND	\$8.50
	BLACK / GRAY	MIDSIZE	53g	0.600	ROUND	\$8.50

CLUB GRIPS



SUPERSTROKE



MODEL	COLOR	SIZE	WEIGHT	BUTT SIZE	TYPE	UPCHARGE
REVL COMFORT	BLACK / GRAY	STANDARD	54g	0.600	ROUND	\$8.50
	BLACK / GRAY	MIDSIZE	64g	0.600	ROUND	\$8.50



MODEL	COLOR	SIZE	WEIGHT	BUTT SIZE	TYPE	UPCHARGE
CROSSLINE 2.0	BLACK / GRAY	STANDARD (+4)	49.5g	0.600	ROUND	\$6.50
	BLACK / GRAY	MIDSIZE (+4)	64g	0.600	ROUND	\$6.50
	BLACK / GRAY	JUMBO (+4)	81g	0.600	ROUND	\$6.50



MODEL	COLOR	SIZE	WEIGHT	BUTT SIZE	TYPE	UPCHARGE
CROSSLINE 2.0 CORD	BLACK / WHITE	STANDARD	49g	0.600	ROUND	\$10.00
	BLACK / WHITE	MIDSIZE	59g	0.600	ROUND	\$10.00

WINN



MODEL	COLOR	SIZE	WEIGHT	BUTT SIZE	TYPE	UPCHARGE
DRI-TAC 2.0	BLACK / BLUE	UNDERSIZE	38g	0.600	TEXTURE	\$10.00
DRI-TAC 2.0	BLACK / RED	STANDARD	51g	0.600	TEXTURE	\$10.00
DRI-TAC 2.0	BLACK / BLUE	MID-SIZE	54g	0.600	TEXTURE	\$10.00
DRI-TAC 2.0	BLACK / GRAY	JUMBO	56g	0.600	TEXTURE	\$10.00

PUTTER GRIPS



GOLF PRIDE



MODEL	COLOR	SIZE	WEIGHT	TYPE	UPCHARGE
TM PISTOL	BLACK / WHITE	STANDARD	71g	PUTTER	\$0.00



MODEL	COLOR	SIZE	WEIGHT	TYPE	UPCHARGE
REVERSE TAPER PISTOL	BLACK/WHITE	STANDARD	64g	PUTTER	\$30.00

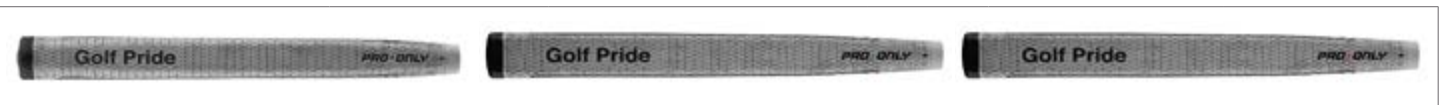

MODEL	COLOR	SIZE	WEIGHT	TYPE	UPCHARGE
PRO ONLY CORD - GREEN STAR 88CC	GREY/BLACK	STANDARD	90g	PUTTER	\$20.00
PRO ONLY CORD - BLUE STAR 81CC	GREY/BLACK/BLUE	STANDARD	88g	PUTTER	\$20.00
PRO ONLY CORD - RED STAR 72CC	GREY/BLACK/RED	STANDARD	78.5g	PUTTER	\$20.00

LAMKIN



MODEL	COLOR	SIZE	WEIGHT	TYPE	UPCHARGE
DEEP-ETCHED	BLACK	STANDARD	81g	PUTTER	\$10.00



MODEL	COLOR	SIZE	WEIGHT	TYPE	UPCHARGE
SINK FIT SKINNY	BLACK/SILVER	STANDARD	70g	PUTTER	\$0.00
SINK FIT SKINNY	NAVY	STANDARD	70g	PUTTER	\$0.00



MODEL	COLOR	SIZE	WEIGHT	TYPE	UPCHARGE
DEEP ETCHED PISTOL	BLACK	STANDARD	81g	PUTTER	\$5.00



MODEL	COLOR	SIZE	WEIGHT	TYPE	UPCHARGE
DEEP SMOOTH	BLACK/BLUE	STANDARD	81g	PUTTER	\$-

PUTTER GRIPS



SUPERSTROKE



MODEL	COLOR	SIZE	WEIGHT	TYPE	UPCHARGE
GTR 1.0	WHITE / YELLOW	MIDSIZE	83g	PUTTER	\$0.00
GTR 1.0	GRAY / WHITE	MIDSIZE	83g	PUTTER	\$0.00
GTR 1.0	WHITE / RED	MIDSIZE	83g	PUTTER	\$0.00
GTR 1.0	WHITE	MIDSIZE	83g	PUTTER	\$0.00
GTR 1.0	SILVER	MIDSIZE	83g	PUTTER	\$0.00
GTR 1.0	BLUE	MIDSIZE	83g	PUTTER	\$0.00
GTR 1.0	BLACK	MIDSIZE	84g	PUTTER	\$0.00



MODEL	COLOR	SIZE	WEIGHT	TYPE	UPCHARGE
ZENERGY PISTOL 1.0	BLACK/WHITE	STANDARD	58g	PUTTER	\$20.00



MODEL	COLOR	SIZE	WEIGHT	TYPE	UPCHARGE
ZENERGY TOUR 2.0	WHITE/BLACK	OVERSIZE	55g	PUTTER	\$20.00
ZENERGY TOUR 3.0	WHITE/BLACK	OVERSIZE +	93g	PUTTER	\$20.00



MODEL	COLOR	SIZE	WEIGHT	TYPE	UPCHARGE
ZENERGY FLATSO 2.0	BLACK/WHITE	OVERSIZE	50g	PUTTER	\$20.00

DRIVER/WY SHAFTS

HYBRID SHAFTS

IRON SHAFTS

WEDGES

PUTTERS

SWING GRIPS

PUTTER GRIPS

BUILD

JUNIOR



PUTTER GRIPS



SUPERSTROKE



MODEL	COLOR	SIZE	WEIGHT	TYPE	UPCHARGE
2.0 XL WHITE SPIDER	WHITE	OVERSIZE	77g	PUTTER	\$0.00
2.0 XL BLACK SPIDER	BLACK	OVERSIZE	77g	PUTTER	\$0.00
3.0 17" WHITE SPIDER	WHITE/BLACK	OVERSIZE	93g	PUTTER	\$0.00
3.0 17" BLACK SPIDER	BLACK/WHITE	OVERSIZE	93g	PUTTER	\$0.00



MODEL	COLOR	SIZE	WEIGHT	TYPE	UPCHARGE
ZENERGY 2.0 CLAW	WHITE/BLACK	MIDSIZE	63g	PUTTER	\$20.00



MODEL	COLOR	SIZE	WEIGHT	TYPE	UPCHARGE
1° OFF-AXIS PISTOL 1.0 (SPIDER ZT) RH & LH	BLACK/WHITE	STANDARD	84g	PUTTER	\$0.00
2° OFF-AXIS TOUR 2.0	BLACK/WHITE	OVERSIZE	56g	PUTTER	\$0.00



MODEL	COLOR	SIZE	WEIGHT	TYPE	UPCHARGE
3.0 17" (SPIDER ZT COUNTER BALANCE -38")	BLACK/WHITE	OVERSIZE	93g	PUTTER	\$0.00
2.0 XL 13.75" (SPIDER ZT COUNTER BALANCE -36")	BLACK/WHITE	OVERSIZE	77g	PUTTER	\$0.00



MODEL	COLOR	SIZE	WEIGHT	TYPE	UPCHARGE
'26 PISTOL 1.0	BLACK/WHITE	STANDARD	88g	PUTTER	\$0.00

DRIVER/WY SHAFTS

HYBRID SHAFTS

IRON SHAFTS

WEDGES

PUTTERS

SWING GRIPS

PUTTER GRIPS

BUILD

JUNIOR



TAYLORMADE JUNIOR SPEC EQUIPMENT



As your game grows, so should your equipment. TaylorMade introduces customized Junior Spec clubs, delivering premium in-line products fit for the intermediate junior golfer. It ensures high-level performance throughout the bag for the competitive or aspiring player dedicated to improving. Junior Spec clubs are the gateway to a higher level of golf.

DETAILS:

TaylorMade's Junior Spec offerings include more than a dozen shaft options and every in-line TaylorMade product. Shorter lengths and lighter swingweights make them fully customizable for junior golfers who have outgrown boxed sets, but are not quite ready for full-length equipment. Additional grip offerings and a range of loft/lie options allow for precision fit equipment that helps the golfer unlock their full potential.



DRIVERS	LENGTH
QI4D LS DRIVER	40"
QI4D DRIVER	40"
QI4D MAX DRIVER	40"



FAIRWAY	LENGTH
QI4D MAX #3	38"
QI4D MAX #5	37"
QI4D #3 / #3HL	38"
QI4D #5	37"
QI4D #7	36"
QI4D #9	35"



RESCUE	LENGTH
QI4D #3	36"
QI4D #4	35"
QI4D #5	34"
QI4D #6	33.5"
QI4D #7	33"



PUTTERS	LENGTH
ALL MODELS	31"



PUTTERS	LENGTH
ALL MODELS	31"

P-700 SERIES

P-790 / P-770 / P-7CB / P-7MB



IRON	LENGTH
4	33.5"
5	33"
6	32.5"
7	32"
8	31.5"
9	31"
PW	30.75"
AW	30.5"



IRON	LENGTH
4	34.13"
5	33.5"
6	32.88"
7	32.25"
8	31.75"
9	31.25"
PW	30.75"
AW	30.5"
SW	30.25"
LW	30"



WEDGE	LENGTH
46	31"
50	30.75"
52	30.75"
54	30.5"
56	30.5"
58	30.25"
60	30.25"

ADJUSTMENTS AVAILABLE IN CUSTOM

LOFT ADJUSTMENTS (IRONS/WEDGES)	+/-2°
LIE ADJUSTMENTS (IRONS/WEDGES)	+/-4°
LENGTH ADJUSTMENTS	-1° TO +2°

Loft and lies specifications mirror current stock specs for Mens / Womens

SHAFTS - DRIVER / FAIRWAY



MODEL	FLEX
VANQUISH 40	R2-A
VANQUISH 40	R
VANQUISH 50	R



MODEL	FLEX
REAX 50 MR	R
REAX 50 MR	A



MODEL	FLEX
REAX 40 MR	A



MODEL	FLEX
REAX 40 MR	L



MODEL	FLEX
CYPHER 40 4.0	L
CYPHER 40 5.0	A
CYPHER 50 5.5	R

SHAFTS - RESCUE



MODEL	FLEX
HZRDUS ORANGE	JR



MODEL	FLEX
VANQUISH 40	R2-A
VANQUISH 40	R
VANQUISH 50	R



MODEL	FLEX
REAX 55	A
REAX 65	R
REAX 50 HL	S



MODEL	FLEX
REAX 40 HL	L

GRIPS



MODEL
GOLF PRIDE TOUR VELVET JUNIOR
GOLF PRIDE TOUR VELVET 360

SHAFTS - IRONS



MODEL	FLEX
HZRDUS ORANGE	JR



MODEL	FLEX
REAX 55	A
REAX 65	R
REAX 50 HL	A



MODEL	FLEX
REAX 45 HL	L



MODEL	FLEX
KBS MAX GRAPHITE 65	R
KBS MAX GRAPHITE 55	A
KBS MAX GRAPHITE 45	L



MODEL	FLEX
UST RECOIL DART ESX	R (F3)
UST RECOIL DART ESX	A (F2)
UST RECOIL DART ESX	L (F1)



MODEL	FLEX
KBS 580	JNR

DRIVER RECOMMENDATION

HEIGHT	SHAFT LENGTH ADJUSTMENT	DRIVER LOFT	SHAFT FLEX
4'-4'4"	-1"	12°	Jnr Flex
4'5"-4'8"	STD	12°	Jnr Flex
4'9"-5'	+1"	10.5° / 12°	Jnr / L Flex
5'1"-5'4"	+2"	10.5° / 12°	L Flex / A Flex

FAIRWAY RECOMMENDATION

HEIGHT	SHAFT LENGTH ADJUSTMENT	FW LOFT	SHAFT FLEX
4'-4'4"	-1"	5W / 7W	Jnr Flex
4'5"-4'8"	STD	5W / 7W	Jnr Flex
4'9"-5'	+1"	5W	Jnr / L Flex
5'1"-5'4"	+2"	5W	L Flex / A Flex

RESCUE RECOMMENDATION

HEIGHT	SHAFT LENGTH ADJUSTMENT	RESCUE LOFT	SHAFT FLEX
4'-4'4"	-1"	#6-#7	Jnr Flex
4'5"-4'8"	STD	#6-#7	Jnr Flex
4'9"-5'	+1"	#5-#6	Jnr / L Flex
5'1"-5'4"	+2"	#5-#6	L Flex / A Flex

IRON RECOMMENDATION

HEIGHT	SHAFT LENGTH ADJUSTMENT	LOFT ADJUSTMENT	LIE ADJUSTMENT	SHAFT FLEX
4'-4'4"	-1"	2° Weak	4° Flat	Jnr Flex
4'5"-4'8"	STD	2° Weak	2° Flat	Jnr Flex
4'9"-5'	+1"	1° Weak	STD Lie	Jnr / L Flex
5'1"-5'4"	+2"	STD	STD Lie	L Flex / A Flex